

TEXAS A&M INTERNATIONAL UNIVERSITY



SAFETY MANUAL

TABLE OF CONTENTS

Texas A&M International University
Environmental Health and Safety (EH&S)

I	Introduction	1
1	Environmental Health and Safety	1
2	Employees and Students	2
3	Administration	2
4	Supervisors, Department Heads and Directors	2
5	Faculty, staff and Students	2
6	Safety Manual	3
II	General Safety	4
1	Accident Reporting	4
2	Americans with Disabilities (ADA)	4
3	Asbestos	5
4	Appropriate Apparel	6
5	Graphic Arts Media	6
6	Solvents	6
7	Aerosol Sprays	7
8	Acids and Alkalis	7
9	Paints and Pigments	7
10	Photography	8
11	Plastics, Acrylics, Epoxy Resins	8
12	Pottery and Ceramics	9
13	Woodworking	9
14	Hearing Conservation Program	9
15	Hearing Loss	10
16	Heat Stress and Heat Strain	12
17	Heat Exhaustion	12
18	Heat Stroke	13
19	Housekeeping	14
20	Indoor Air Quality	14
21	Lead Paint	16
22	Lifting	16
23	Polychlorinated Biphenyls (PCBs)	18
24	Preventing Slips and Falls	19
25	Smoking	20
26	Visitor Safety	20
III	Office Safety	21
1	General Office Safety	21
2	Good Housekeeping Practices	21
3	Hazardous Objects and Materials	22
4	Preventing Cuts and Punctures	22
5	Preventing Machine Accidents	22
6	Preventing Slips and Falls	23

TABLE OF CONTENTS

7	Preventing Stress	24
8	Equipment and Furniture Safety	24
9	Work Station Arrangement	27
10	Operator's Position	27
11	Equipment Arrangement	28
IV	<i>Shop Safety</i>	30
1	General Shop Safety	30
2	Personal Protection	30
3	Job Safety	31
4	Safety Guidelines	32
5	Hand Tools	33
6	Insulation	34
7	Ladders	34
8	Power Tools	34
9	Guards	36
10	Safety Guidelines (needs to be renamed)	37
11	Drill Press Safety	37
12	Grinder Safety	38
13	Hot Work Permit	38
14	Jointer and Shaper Safety	40
15	Lathe Safety	40
16	Nail/Air Gun Safety (Pneumatic Fastening Tools)	41
17	Planer Safety	42
18	Forging Machines	42
19	Sander Safety	43
20	Saw Safety	43
21	Spray Paint Booths	44
22	Welding and Cutting	45
23	Welding Guidelines	46
24	Cutting Guidelines	47
V	<i>Electrical Safety</i>	48
1	General Electrical Safety	48
2	Definitions	48
3	Circuit Breaker Loads	49
4	Electrical Grounding	49
5	Electrical Panels	50
6	Electrical Safety Guidelines	50
7	Electrical Emergency Response	51
8	Lockout/Tag-out Procedures	52
9	High Voltage Procedures	56
10	Minimum Clear Working Space	57
VI	<i>Construction Safety</i>	58
1	General Construction Guidelines	58
2	Barriers and Guards	58
3	Types of Barriers and Guards	58
4	Areas that Need Barriers or Guards	59
5	Using Barriers and Guards	59

TABLE OF CONTENTS

6	Heavy Equipment Safety	60
7	Forklifts	60
8	Backhoes	61
9	Hoists	62
10	Hoisting Guidelines	62
11	Picking Up Loads with Hoists	62
12	Avoiding Electrical Hazards with Hoists	62
13	Inspecting Hoists	63
14	Mobile Crane Safety Procedures	63
15	Fall Protection Procedures	64
16	Scaffolding	73
17	Trenching	74
VII	<i>Confined Space</i>	85
1	Policy	85
2	Reason	85
3	Definition and Locations	85
4	Examples of a Confined Space	86
5	Training	86
6	Work in a Confined Space	86
VIII	<i>Fire & Life Safety</i>	87
1	Program Requirement	87
2	Applicable Codes & Standards	87
3	Fire and Life Safety Program	87
4	Appliances	88
5	Arson	88
6	Building Evacuations/Drills	88
7	Candles & Incense	89
8	Combustible Storage	89
9	Compressed Gas Cylinders	90
10	Construction and Renovation	90
11	Decorations	90
12	Electrical Safety	91
13	Emergency Access and Egress	91
14	Flammable and Combustible Liquids	92
15	Fire Detection and Notification	93
16	Fire Doors	94
17	Fire Extinguishers	95
18	Fire Hydrants	97
19	Fire Lanes	97
20	Fire and Life Safety Inspections	97
21	Fire Prevention	98
22	Fire Reporting	98
23	Fire Suppression	99
24	Liquefied Petroleum Gas (LPG)	100
25	Open Burning	101
26	Pyrotechnics/Open Flames	102
27	Smoking	102
28	Space Heaters	102

TABLE OF CONTENTS

<i>IX</i>	<i>Emergency Management</i>	103
1	Purpose	103
2	Phases of Emergency Management	103
3	Roles and Responsibilities	103
4	Summoning Emergency Services	105
5	Training Resources	106
6	Warning Systems	106
<i>X</i>	<i>Personal Protective Equipment</i>	108
1	Personal Protective Equipment Defined (PPE)	108
2	Arm and Hand Protection	108
3	Body Protection	109
4	Ear and Hearing Protection	109
5	Eye and Face Protection	110
6	Foot Protection	110
7	Head Protection	111
8	Respiratory Protection Program	111
9	Respiratory Usage Requirements	112
10	Respiratory Selection	112
11	Respiratory Safety	112
<i>XI</i>	<i>Laboratory Safety</i>	115
1	General Safety Guidelines	115
<i>XII</i>	<i>Biological Safety</i>	116
1	Biological Safety Program	116
<i>XIII</i>	<i>Chemical Safety</i>	117
1	Overview	117
2	Hazard Communication Program	117
3	Hazard Identification	118
4	Chemical Safety Guidelines	119
5	Material Safety Data Sheets	120
6	Safe Handling Guidelines	121
7	Chemical Storage Guidelines	122
8	Hygiene and Chemical Safety	124
9	Types of Chemical Hazards	125
10	Protecting Oneself When Working with Chemicals	137
11	Chemical Waste Disposal	137
12	Transporting Hazardous Materials	137
<i>XIV</i>	<i>Agriculture Safety</i>	138
1	Introduction to Agricultural Safety	138
2	General Tips for a Safe Working Environment	138
3	Remember the Following Points	139
4	General Farm Equipment Safety	139
5	Farmstead Equipment	140
6	Farm Field Equipment	140
7	Grain Augers	140
8	Hydraulic Equipment Safety	140
9	Guards, Shields and PTO's	141
10	Fuel Storage	141
11	Stationary Fuel Storage Tanks	141

TABLE OF CONTENTS

12	Portable Fuel Tanks	142
13	Liquefied Petroleum Gas	142
14	Grain Storage	143
15	General Tractor Safety	144
16	Tractor Driving Safety	144
17	Roll-over Protective Structures (ROPs)	146
18	Bypass Starting	148
19	Towing Safety	149
20	Tractor Hauling Safety	150
21	Pesticide Chemical Safety	150
22	General Pesticide Safety	152
23	Preparing to Apply Pesticides	153
24	Mixing Pesticides	154
25	Applying Pesticides	154
26	Pesticide Storage and Disposal	155
27	Site Storage	155
28	Storage Facility	155
29	Operational Procedures	156
30	Pesticide Safety Precautions	156
31	Fire Control, Pesticide	156
32	Disposal, Pesticide	157
33	Cleanup, Pesticide	157
34	Antidotes, Pesticide	157
35	Fertilizer Chemical Safety	157
36	Fertilizer Safety Precautions	158
37	Storing Ammonium Nitrate	158
XV	<i>Radiation Safety</i>	160
1	Magnetic Resonance Imaging	160
XVI	<i>Vehicle Safety</i>	161
1	Utility Vehicle Operating Procedures Program	161
2	General Vehicle Safety	163
3	Defensive Driving	164
4	Backing Vehicles	165
5	Accidents	165
6	Railroad Crossings	166
7	Bicycle Safety	167
XVII	<i>Grounds Maintenance</i>	168
1	General Lawn Safety	168
2	Hand Tools	169
3	Mower Safety	169
4	Riding Lawn Mowers	170
5	Walk-Behind Mowers	170
6	Chain Saw Safety	171
7	Power Blowers	172
8	Trimming Equipment	172
9	Chemical Products	172

TABLE OF CONTENTS

XVIII	<i>Environmental Management</i>	173
1	Environmental Management	173
2	Hazardous Waste Program	173
3	Pollution Prevention Plan	173
4	Storm Water Management	173
5	Spill Prevention Control and Countermeasures	174
XIX	<i>Hazardous Materials Transportation</i>	175
1	General	175
2	The Regulations	175
3	Who Needs Training	175
4	What Training is Offered	176
5	Hazardous Materials Defined	177
6	DOT Requirements Simplified	177
7	Hazardous Materials Shipping Questions	177

I. INTRODUCTION

1.0 TAMIU Environmental Health & Safety

1.1 TAMIU Environmental Health & Safety is responsible for managing safety and health programs for Texas A&M International University and also for working with the other Texas A&M International University System components in development of local safety programs. The overall objective is to maximize the safety and health of employees, students and visitors campus wide.

1.2 Programs and services provided by TAMIU Environmental Health & Safety include the following:

1.2.1 Monitor safety regulations

1.2.2 Develop policies and/or protocols concerning safety and health issues

1.2.3 Disseminate information concerning safety regulations, policies, and protocols

1.2.4 Submit reports and other required documentation to pertinent state agencies

1.2.5 Evaluate facilities to maintain safe work environments

1.2.6 Inspect/test safety equipment such as fire extinguishers and fume hoods

1.2.7 Report results of evaluations, tests, etc., along with recommended corrective measures to appropriate personnel for action

1.2.8 Dispose of hazardous waste

1.2.9 Review construction plans for compliance with codes and standards

1.2.10 Respond to emergencies such as fires or chemical spills

1.2.11 Measure environmental parameters such as vapors or noise

1.2.12 Provide safety-related training

1.2.13 Evaluate injury reports for accident trends and perform investigations as appropriate

1.2.14 Maintain Material Safety Data Sheets (MSDS) as an information resource on hazardous materials

1.2.15 Assist with emergency preparedness planning for major disasters and coordinate University plans with the local community

1.2.16 Assist departments in the development of Emergency Evacuation Plans

1.2.17 Participate in safety committees and task forces

1.2.18 Publish the Safety Dispatch newsletter

1.2.19 Maintain a library of safety audiovisual programs and relevant safety regulations and nationally recognized codes and standards



2.0 Employees and Students

- 2.1 All University employees and students are responsible and accountable for safety performance and environmental protection.

3.0 TAMIU Administration

- 3.1 The TAMIU Administration is responsible for the following:

- 3.1.1 Providing the facilities and equipment required for a safe work environment
- 3.1.2 Reviewing and approving health and safety policies and protocols
- 3.1.3 Correcting safety deficiencies by establishing priorities and committing resources, as appropriate
- 3.1.4 Making “working safely” a condition of employment.



4.0 Supervisors, Department Heads, and Directors

- 4.1 Supervisors, Department Heads, and Directors are responsible for the following:

- 4.1.1 Promoting safety and loss prevention
- 4.1.2 Eliminating or controlling occupational hazards
- 4.1.3 Periodically conducting safety and loss control evaluations
- 4.1.4 Ensuring that employees are adequately trained in safety policies and protocols
- 4.1.5 Ensuring that employees are provided with appropriate personal protective clothing and equipment for safe job performance
- 4.1.6 Perform accident investigation, as necessary.



5.0 Faculty, Staff, and Students

- 5.1 Faculty, staff, and students are responsible for the following:

- 5.1.1 Performing their jobs in the safest prescribed manner
- 5.1.2 Eliminating and/or reporting workplace hazards
- 5.1.3 Reporting accidents, incidents, and unsafe practices or conditions to supervisors
- 5.1.4 Complying with safety and health policies and protocols

6.0 TAMIU Safety Manual

6.1 The Texas A&M International University Safety Manual has been developed by TAMIU Environmental Health & Safety as a reference manual. It describes programs, practices, and procedures to be followed to help ensure a safe and healthy environment. It is the intent of the University to comply with all relevant occupational and environmental regulations and nationally recognized codes and standards. Using the manual's protocols will complement responsible efforts to foster safe work habits and to maintain safe work environments.

END OF SECTION

II. GENERAL SAFETY

1.0 Accident Reporting

1.1 An accident is an unplanned occurrence that may result in damage to people, property, equipment, or the environment. When accidents are reported promptly, injured employees, students, and visitors receive timely medical care and unsafe conditions receive prompt corrective action. Environmental Health & Safety investigates accidents to identify accident trends, determine the effectiveness of current safety programs, and prevent future accident.



1.2 **IMPORTANT:** Report all accidents to your supervisor, Environmental Health & Safety, or the University Police Department, as appropriate. If an injury or exposure occurs on-the-job, complete the [WCI Form, Employer's First Report of Injury or Illness](#).

1.3 **EXAMPLE:** Report hazards, such as missing manhole covers or chemical spills, to Environmental Health & Safety. Report accidents such as vehicle collisions to the University Police Department (UPD).

1.4 Report unsafe conditions or potentially hazardous situations to Environmental Health & Safety as quickly as possible. The Office will then contact other departments and outside agencies as appropriate

2.0 Americans with Disabilities Act (ADA)

2.1 Within the standards required by the ADA, TAMIU makes reasonable accommodations for persons with disabilities so that they may more fully participate in programs and the benefits of employment. Safety is an important consideration in providing accommodations.

2.2 Elevators, automated door openers, lifts, ramps, etc., facilitate access. Sometimes this equipment becomes damaged or does not function properly. Please promptly notify the building proctor and/or facility coordinator who will contact Physical Plant for equipment repair.



2.3 Handicap parking, sidewalks, wheelchair ramps, and building entrance areas may become blocked or congested with illegally parked bicycles, vehicles, or campus construction. Please contact Transportation Services to report bicycle or vehicle related safety concerns. For construction related issues, please contact Physical Plant.

- 2.4 Many classrooms are equipped with wheelchair accessible desks or tables, sometimes with chairs that can be removed or replaced as needed. Wheelchairs or removable chairs that block aisles and exits create an unacceptable hazard. Please report instances to the person presenting the class or to Environmental Health and Safety.
- 2.5 Braille signage assists persons with visual disabilities locate elevators, stairs, exits, classrooms, laboratories, restrooms, etc. The absence of signage could pose a safety issue if a person is not able to locate a specific area, e.g., an emergency exit, or inadvertently enters an inappropriate area. Contact the building proctor or facility coordinator regarding Braille signage needs. Physical Plant prepares and installs Braille signage.
- 2.6 Building evacuation plans should incorporate procedures for assisting persons with mobility disabilities or impairments to safely vacate the facility. The procedures should be communicated among the building proctor and/or facility coordinator and other personnel in the building assigned with emergency response duties. Contact Environmental Health and Safety or Safety and Security for advice in emergency preparedness.

3.0 Asbestos

- 3.1 Asbestos is a mineral fiber that causes cancer and various respiratory illnesses. Older buildings constructed prior to 1980 may contain asbestos. Asbestos is commonly found in older appliances, insulation, shingles, siding, putties, and caulking. Generally, it is not a problem unless the material that contains it crumbles or flakes.
- 3.2 The Texas Asbestos Health Protection Rules do not require building owners to conduct inspections and identify all asbestos locations. Inspections are required, however, prior to renovation or dismantling activities.



- 3.3 **NOTE:** *Call the Physical Plant before performing work on campus that will disturb building fixtures, walls, or ceiling (e.g., installing computer cables in the ceiling). The Physical Plant will help ensure that the work does not affect asbestos containing materials.*
- 3.4 **IMPORTANT:** *Do not handle asbestos or suspected asbestos or try to remove it yourself.*
- 3.5 Depending on the size of the project, either the TAMIU Facilities Planning & Construction or the Physical Plant handles contracts for consultation and/or abatement. Direct any questions about identifying or removing asbestos to the

Physical Plant. Address any safety-related questions to Environmental Health & Safety.

4.0 Appropriate Apparel

- 4.1 Dress in a manner that does not impair safety. Loose clothing, long hair, dangle jewelry, and sandals may be dangerous around moving equipment.
- 4.2 Always wear clothing that is appropriate for your job. Refer to the chapters on Personal Protective Equipment and Office Safety for more information.



5.0 Graphic Arts Media

- 5.1 The art supplies and chemicals associated with graphic media are often hazardous. Depending on the type of art supplies used, artists can develop the same types of occupational diseases as industrial workers. Studies show that people who work with hazardous graphic media chemicals improperly can develop a variety of ailments.
- 5.2 The risk of chemical hazards is directly linked to the following factors:
 - 5.2.1 Duration and frequency of exposure
 - 5.2.2 Chemical toxicity
 - 5.2.3 Chemical amount
- 5.3 Workers are exposed to graphic media hazards through skin contact, inhalation, and ingestion.
- 5.4 Follow these safety guidelines for working with graphic media materials:
 - 5.4.1 Wear protective clothing and follow MSDS, as appropriate.
 - 5.4.2 Use nontoxic or less toxic solvents and chemicals when possible.
 - 5.4.3 Eliminate toxic metals such as lead and cadmium. Instead, use cadmium-free silver solders and lead-free paint, glazes and enamels.
 - 5.4.4 Use water-based instead of solvent-based materials.
 - 5.4.5 Use liquid materials to replace powders.
 - 5.4.6 Use wet techniques (such as wet sanding) instead of dry techniques.
 - 5.4.7 Apply coatings by brushing or dipping instead of spraying.
 - 5.4.8 Eliminate cancer-causing chemicals.



6.0 Solvents



- 6.1 Solvents are used to dissolve oils, resins, varnishes, and inks. They are also used to remove paint and lacquer. Due to their common usage, solvents are one of the most underrated media hazards. Most organic solvents are poisonous if swallowed or inhaled in sufficient quantities. They also cause dermatitis and narcosis.
- 6.2 Use the least toxic solvent possible. Denatured or isopropyl alcohol, acetone, and odorless mineral spirits are less toxic than solvents such as chloroform or ethylene.

7.0 Aerosol Sprays

- 7.1 Aerosol sprays, such as fixatives, paint sprays, and adhesive sprays, are extremely dangerous if someone inhales the fine mists produced by these products. Air brushes and spray guns are equally hazardous. Use aerosol sprays in a well-ventilated area and wear a dust/vapor mask to protect you from the hazardous vapors.

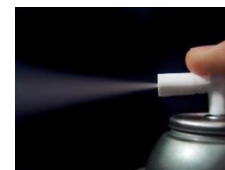

8.0 Acids and Alkalis

- 8.1 The acids and alkalis used in ceramics, photo chemicals, paint removers, and similar materials can be very caustic to the skin, eyes, respiratory system, and gastrointestinal system. Likewise the acids and alkalis used to etch metals and glass can be very dangerous. Strong acids, such as hydrochloric, sulfuric, and perchloric acid, require special handling as outlined in the MSDS. Alkalis, such as caustic potash, caustic soda, quicklime, and unslaked lime, also require special treatment. Remember to add acid to water, not water to acid, when mixing chemicals.



9.0 Paints and Pigments

- 9.1 Many paints and color pigments contain hazardous chemical compounds. Lead paint, for example, is extremely dangerous, and should never be used in its powder form. Other paint components, such as chromate, cadmium, and cobalt pigments, are equally hazardous. Do not inhale powdered paint or spray paint vapors or accidentally ingest pigment by placing the brush tip in your mouth. In addition, do not eat, drink, or smoke while painting. Any of these activities could result in chronic poisoning.
- 9.2 The table below outlines common paint pigments and their hazardous chemical component:



Hazardous Chemical	Pigment (Paint Name)
--------------------	----------------------

Arsenic	Emerald Green Cobalt Violet
Antimony	True Naples Yellow
Cadmium	All Cadmium Pigments
Chromium	Zinc Yellow Strontium Yellow Chrome Yellow
Cobalt	Cobalt Violet Cobalt Green Cobalt Yellow Cerulean Blue
Lead	Falk White Lead White Creminitz White Mixed White
Manganese	Manganese Blue Manganese Violet Burnt Umber Raw Umber Mars Brown
Mercury	Vermilion Cadmium Vermilion Red

10.0 Photography



- 10.1 Many of the chemicals used for photographic processing can cause severe skin and lung problems. The greatest hazards associated with photography include the preparation and use of concentrated chemical solutions. Never touch chemical powders or solutions with unprotected hands. In addition, take care not to stir up and inhale chemical dusts.
- 10.2 **IMPORTANT:** *Good ventilation is essential when working with photographic chemicals.*
- 10.3 The following are common photographic agents and their hazards:
- 10.3.1 Developer: May cause skin irritation and allergic reactions.
 - 10.3.2 Stop-bath: May cause burns and throat irritation.
 - 10.3.3 Fixer: Highly irritating to lungs.
 - 10.3.4 Intensifier: Very corrosive and may cause lung cancer.
 - 10.3.5 Reducer: Contact with heat, concentrated acids, or ultraviolet radiation produces poisonous gas.
 - 10.3.6 Toners: Highly toxic.
 - 10.3.7 Hardeners and stabilizers: Often contain formaldehyde which is poisonous, a skin irritant, and a known carcinogen.

11.0 Plastics, Acrylics, Epoxy Resins

- 11.1 Plastic hazards result from making plastic and working with finished plastic. The greatest hazards associated



with making plastic come from the monomers, solvents, fillers, catalysts, and hardeners that are commonly toxic. The hazards involved with finished plastics result mainly from the methods used to work the plastic. For example, overheating or burning plastic produces toxic gases. Polishing, sanding, and sawing plastic produces harmful dusts.

- 11.2 Certain types of plastics, such as acrylics and epoxy resins are also hazardous. The components in acrylic, for example, include irritants, explosives, and flammables. The main hazard associated with acrylic compounds, however, is inhalation. Always maintain good ventilation when working with acrylic.
- 11.3 The epoxy resins used in laminating, casting, glues, and lacquer coatings, are also skin irritants, sensitizers, and suspected cancer-causing agents. Avoid skin contact and inhalation when working with epoxy resins.

12.0 Pottery and Ceramics

- 12.1 Pottery clay contains silicates that can be hazardous if inhaled. Many low-fire clays and slip-casting clays also contain talc, which may be contaminated with asbestos. Long-term inhalation of asbestos can cause cancer and respiratory diseases. When mixing clay dust or breaking up dry grog, use exhaust ventilation and/or wear a toxic dust respirator. Work with wet clay when possible.



- 12.2 Pottery glazes also contain free silica, including flint, feldspar, and talc. Wear a toxic dust respirator when mixing or spraying glazes.
- 12.3 Toxic fumes and gases are often produced during the firing process. Ensure that all kilns are ventilated. In addition, use infrared goggles or a shield to look in the kiln peep hole. Proper eye protection will help prevent cataracts.

13.0 Woodworking

- 13.1 The hazards associated with woodworking include sawdust inhalation, exposure to toxic solvents and adhesives, and excessive noise from woodworking tools. Long term inhalation of sawdust can cause chronic respiratory diseases. Depending on the type of wood, short term sawdust inhalation may also produce allergic reactions. Toxic preservatives, such as arsenic compounds and creosote, may cause cancer and reproductive problems. Epoxy resins and solvent-based adhesives, also pose potential hazards. Use dust collectors around woodworking machines, ensure proper ventilation, and wear personal protective equipment, as appropriate.



14.0 Hearing Conservation Program

14.1 Excessive noise levels may permanently damage a person's hearing. Whenever possible, employees should avoid noise exposure or reduce noise to an acceptable level. The following table outlines ACGIH limits for acceptable noise exposure indicated as decibels (dB) and time limits. At no time should any exposure to continuous, intermittent, or impact noise in excess of 140dB be allowed.

Duration/Day (Hours)	Sound Level (dB)
8	85
4	88
2	91
1	94
1/2 (30 minutes)	97
1/4 (15 minutes)	100
7 minutes	103
3 minutes	106
1 minute	109
Less than 1 minute	112 +

15.0 Hearing loss can be permanent — wear protective equipment when noise levels are high.

15.1 Before using personal protective equipment, such as ear plugs or muffs, to reduce noise exposure, try to reduce noise levels by changing work procedures. Maintenance practices such as the following can reduce noise levels:

- 15.1.1 Replacing worn or loose machine parts
- 15.1.2 Performing high-noise operations during hours when people are less likely to be affected
- 15.1.3 Maintaining and lubricating equipment to eliminate rattles and squeaks
- 15.1.4 The following table from the CDC illustrates



various noise levels:

	DECIBEL - dB(A)	EQUIPMENT
Double protection recommended above 105 dB(A)	112	Pile driver
	110	Air arcing gouging
	108	Impact wrench
	107	Bulldozer - no muffle
	102-104	Air grinder
	102	Crane - uninsulated cab
	101-103	Bulldozer - no cab
	97	Chipping concrete
	96	Circular saw and hammering
	96	Jack hammer
Hearing protection recommended above 85 dB(A)	96	Quick-cut saw
	95	Masonry saw
	94	Compactor - no cab
	90	Crane - insulated cab
	87	Loader/backhoe - insulated cab
	86	Grinder
	85-90	Welding machine
	85	Bulldozer - insulated cab
	60-70	Speaking voice

Table 1: Some typical noise levels found on construction sites

15.2 Engineering controls, such as the following, can also reduce noise levels:

- 15.2.1 Replacing noisy materials
- 15.2.2 Using large, low speed fans
- 15.2.3 Considering the noise level of new equipment or processes before purchasing or implementing
- 15.2.4 Placing heavy machines on rubber mountings
- 15.2.5 Using sound-absorbing acoustical tiles or baffles
- 15.2.6 Placing noisy machinery or operations in a separate area or room
- 15.2.7 Enclosing noisy conveyors
- 15.2.8 Provide and maintain signage at entrances to high noise areas

15.3 Areas that may require hearing protection include machine shops, the power plant, landscape maintenance, etc. Supervisors should insure that a variety of hearing protection is provided to allow employees sufficient choice. Observe all warning signs and wear hearing protection whenever necessary. Do not interfere with, remove, or modify noise abatement equipment. Keep all equipment properly maintained, and report any malfunctions immediately.



15.4 Environmental Health and Safety will select and monitor employees annually to determine potential noise exposure, and provide hearing tests (audiograms) at no charge to employees exposed to high noise levels in the work area. In addition,

EHSD will conduct noise monitoring of equipment and work areas to aid in determining potential noise exposure.

- 15.5 Refer to the chapter on Personal Protective Equipment for more information on hearing protection. Direct all questions regarding hearing conservation to Environmental Health & Safety.

16.0 Heat Stress and Heat Strain

- 16.1 People may suffer from heat related illnesses at any time of the year but particularly during hot, humid conditions. Because the climate at TAMIU is conducive to these conditions, people must take preventive measures to reduce their risk. To prevent heat related illness, supervisors must assist workers in acclimating to conditions which could cause heat related illness. Employees should limit strenuous physical activity during the hottest portion of the day, wear a brimmed hat when in the sun, take frequent breaks, and drink plenty of fluids.
- 16.2 Examples of heat related illnesses are heat exhaustion heat stroke, heat cramps, dehydration and heat rash.

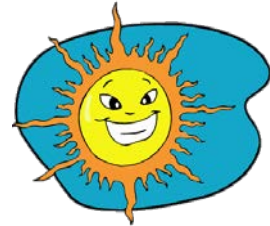

17.0 Heat Exhaustion

- 17.1 Heat exhaustion is usually caused by strenuous physical activity and hot, humid conditions. Because heat exhaustion is the body's response to insufficient water and salt, it should be treated as quickly as possible.
- 17.2 Signs and symptoms of heat exhaustion include the following:
- 17.2.1 Exhaustion and restlessness
 - 17.2.2 Headache
 - 17.2.3 Dizziness
 - 17.2.4 Nausea
 - 17.2.5 Cold, clammy, moist skin
 - 17.2.6 Pale face
 - 17.2.7 Cramps in abdomen and lower limbs
 - 17.2.8 Fast, shallow breathing
 - 17.2.9 Rapid, weak pulse
 - 17.2.10 Falling body temperature
 - 17.2.11 Fainting
- 17.3 Take the following steps to administer first aid for heat exhaustion:
- 17.3.1 Have the victim lie down in a cool or shaded place.



- 17.3.2 If the victim is conscious, have him/her slowly sip cool water.
- 17.3.3 If the victim is unconscious or is conscious but does not improve, seek medical aid as soon as possible.
- 17.3.4 If the victim is sweating profusely, have him or her sip cool water that contains one teaspoon of table salt per pint of water

18.0 Heat Stroke

- 18.1 Heat stroke is usually caused by exposure to extreme heat and humidity and/or a feverish illness. Heat stroke occurs when the body can no longer control its temperature by sweating. Heat stroke is extremely dangerous and may be fatal if not treated immediately.
- 18.2 The signs and symptoms of heat stroke include the following:
 - 18.2.1 Hot, dry skin
 - 18.2.2 Headache
 - 18.2.3 Dizziness
 - 18.2.4 High temperature
 - 18.2.5 Strong pulse
 - 18.2.6 Noisy breathing
 - 18.2.7 Unconsciousness
- 18.3 Immediately take the following steps to administer first aid for heat stroke:
 - 18.3.1 If possible, move the victim to a cool place.
 - 18.3.2 Seek medical attention as soon as possible.
 - 18.3.3 Remove the victim's clothing.
 - 18.3.4 If the victim is conscious, place him in a half-sitting position and support the head and shoulders.
 - 18.3.5 If the victim is unconscious, place him on the side with the head facing sideways.
 - 18.3.6 Fan the victim and sponge the body with cool water.
- 18.4 Environmental factors
 - 18.4.1 Air temperature
 - 18.4.2 Humidity
 - 18.4.3 Radiant heat source
 - 18.4.4 Air circulation
 - 18.4.5 Work related factors
 - 18.4.6 Work load
 - 18.4.6.1 Type of work
 - 18.4.6.2 Level of physical activity
 - 18.4.6.3 Time spent working
- 18.5 Clothing
 - 18.5.1 Weight (heavy vs. breathable)



- 18.5.2 Color (dark vs. light)
- 18.5.3 Personal protective equipment and clothing
- 18.6 Personal factors
 - 18.6.1 Age
 - 18.6.2 Weight/fitness
 - 18.6.3 Use of drugs, alcohol, caffeine, medication
 - 18.6.4 Prior related illness
- 18.7 Prevention
 - 18.7.1 Drink plenty of fluids
 - 18.7.1.1 Don't rely on your thirst
 - 18.7.1.2 Drink 5-7 ounces every 20 minutes
 - 18.7.2 Acclimatization: adjust to the heat
 - 18.7.2.1 The body takes 3-5 days to get used to the heat
 - 18.7.2.2 Be careful if returning from vacation or absence
 - 18.7.3 Choose proper clothing
 - 18.7.3.1 Choose light colors and lightest weight possible
 - 18.7.3.2 Select proper personal protective equipment
 - 18.7.4 Take heat into account when scheduling tasks
 - 18.7.4.1 Implement work/rest cycles
 - 18.7.4.2 Conduct heaviest tasks early morning or dusk
 - 18.7.5 Eat properly
 - 18.7.6 Sleep and rest

19.0 Housekeeping

- 19.1 Good housekeeping skills are essential for personal safety. TAMIU employees are responsible for reducing potential hazards and keeping their work areas safe and clutter-free. Good housekeeping guidelines include keeping aisles and stairways free from clutter, cleaning spills, minimizing combustibles in workplace and storage areas, and keeping all exits free from obstructions.
- 19.2 Maintain clear and unobstructed access to emergency equipment, such as fire extinguishers, pull stations, eye wash units, showers, etc.
- 19.3 For more specific information on housekeeping, refer to the section in this manual that corresponds to your workplace (i.e., Laboratory Safety, Office Safety, Shop Safety, etc.)

20.0 Indoor Air Quality

- 20.1 Indoor air quality refers to the condition of air within an enclosed workplace. The indoor environment of any building is based on several factors including location, climate, building design, construction techniques, building occupant load, and contaminants.



- 20.2 Four key elements are involved in the development of poor indoor air quality:
- 20.2.1 Outside contaminant sources
 - 20.2.2 Poor ventilation systems
 - 20.2.3 Pollutant pathways
 - 20.2.4 Building usage and occupant load
- 20.3 Outside sources for indoor air contaminants include pollen, dust, mold, industrial pollutants, vehicle exhaust, and unsanitary debris near outdoor air intake vents. Other outdoor agents, such as underground storage tanks or landfills, may also affect indoor air quality
- 20.4 Indoor contaminants are classified according to these categories:
- 20.4.1 Combustion products (e.g., smoke and exhaust fumes)
 - 20.4.2 Volatile organic compounds (e.g., solvents and cleaning agents)
 - 20.4.3 Respiratory particulates (e.g., dust, dirt, and pollen)
 - 20.4.4 Respiratory byproducts (e.g., carbon dioxide)
 - 20.4.5 Microbial organisms (e.g., mold, mildew, fungi, and bacteria)
 - 20.4.6 Radionuclides (e.g., radon)
 - 20.4.7 Odors (e.g., perfume, smoke, mold, and mildew)
- 20.5 Additional examples of indoor contaminants include dust, dirt or microbial growth in ventilation systems, emissions from office equipment, and fumes or odors from any source.
- 20.6 TAMIU follows recognized guidelines for new building ventilation systems and air quality control; however, employees are also responsible for the quality of their indoor air. Because indoor air often contains a variety of contaminants at levels far below most exposure standards, it is difficult to link specific health problems with known pollutants. Employees must minimize all contaminants to reduce the low-level pollutant mixtures that commonly cause health problems.
- 20.7 The following practices will help ensure optimum indoor air quality:
- 20.7.1 Fix leaks and drips. (Moisture promotes microbial [i.e., mold and mildew] growth.)
 - 20.7.2 Report unusual odors to Environmental Health and Safety. Do not use air fresheners to cover the smell.
 - 20.7.3 Ensure that indoor ventilation filters are changed regularly and regular maintenance occurs.
 - 20.7.4 Keep laboratory doors closed.
 - 20.7.5 Minimize chemical and aerosol usage. Ventilate your area when chemical or aerosol usage is required. (These compounds include paint, cleaning agents, hairspray, perfume, etc.)



- 20.7.6 Do not block air ducts to control the temperature in your office.
- 20.7.7 Avoid smoking or cooking in enclosed areas. (Smoking is strictly prohibited within University facilities and vehicles.)

21.0 Lead Paint

- 21.1 According to the Centers for Disease Control, lead poisoning is a leading environmental health risk. Lead accumulation in a person's system may lead to fatigue, sudden behavioral change, abdominal pain, anorexia, chronic headaches, joint aches, depression, anemia, impotence, and severe fetal damage in unborn infants.
- 21.2 Assume buildings that were constructed or painted prior to 1978 may contain lead paint. Because common sources of lead exposure include ingestion (lead paint) or inhalation (lead-containing dust), it is important to identify all areas that contain lead paint. If lead paint flakes or chips, it must be encapsulated or removed by qualified persons.
- 21.3 The following locations should also be inspected for lead paint:
 - 21.3.1 Areas where young children or pregnant women are present
 - 21.3.2 Areas with flaking or deteriorating paint
 - 21.3.3 Areas that were built or painted prior to 1978



NOTE: Lead testing is particularly important before beginning renovation on older buildings.

- 21.4 Contact Environmental Health & Safety if you have any questions about lead paint hazards.

22.0 Lifting

- 22.1 All employees must use proper lifting techniques to avoid injury when lifting heavy objects. In general, employees should seek assistance when lifting objects that weigh 50 pounds or more. Use your good judgment to determine if you need assistance, a dolly, back support belt, or other tool to safely lift an object.
- 22.2 The back supports the weight of the entire upper body. When you lift objects or move heavy loads, your back has to support even more weight. If you exceed your body's natural limits, your back cannot support both your body and the extra load. The excess, unsupported pressure is transferred to the lower back, where injury is imminent. By using the muscles in your arms and legs and exercising proper lifting techniques, you can move loads safely and protect your back from possible injury.



22.3 Follow these guidelines to help avoid back injuries:

22.3.1 Avoid moving objects manually. Plan jobs and arrange work areas so that heavy items may be moved mechanically.

22.3.2 Keep in good physical condition. If you are not used to lifting and vigorous exercise, do not attempt difficult lifting tasks.

22.3.3 Think before you act. Use proper lifting techniques and lifting aides such as back support belts, dollies, etc. Get help if you need it.



22.4 When lifting heavy objects, follow these steps and refer to the illustration below:

22.4.1 Test the object's weight before handling it. If it seems too heavy or bulky, get assistance.

22.4.2 Face the object, place one foot behind the object and one foot along its side.

22.4.3 Bend at the knees.

22.4.4 Get a firm, balanced grip on the object. Use the palms of your hands, and use gloves if necessary.

22.4.5 Keep the object as close to your body as possible. (Pull the load in close before lifting.)

22.4.6 Lift by straightening your legs and slightly unbending your back.

22.4.7 If the object is too heavy or bulky, get help.

22.4.8 Do not twist the back or bend sideways.

22.4.9 Do not perform awkward lifts.

22.4.10 Do not lift objects at arm's length.

22.4.11 When moving objects, proceed with caution through doors and around corners.



23.0 Polychlorinated Biphenyls (PCBs)

23.1 PCBs are found in many oil-based items, electrical fluids, capacitors, light ballasts, and transformers. PCBs are known carcinogens that are toxic to humans through skin exposure, inhalation, and ingestion. PCBs cause skin disorders and they irritate the eyes, ears, nose, and throat.

23.2 Before shipping, handling, or disposing of oil-based products, TAMIU employees must determine if their products contain PCBs. Common trade names for PCBs include the following:

- 23.2.1 Aroclor and Aroclor B
- 23.2.2 Abestol
- 23.2.3 Askarel and Adkarel
- 23.2.4 Chlorextol
- 23.2.5 Chlorinol
- 23.2.6 Clorphen
- 23.2.7 Diaclor
- 23.2.8 Dykanol
- 23.2.9 Elemex
- 23.2.10 Eucarel
- 23.2.11 Hyvol
- 23.2.12 Inerteen
- 23.2.13 No-Flamol
- 23.2.14 Pyranol
- 23.2.15 Pyroclor
- 23.2.16 Saf-T-Kuhl
- 23.2.17 Sanotherm

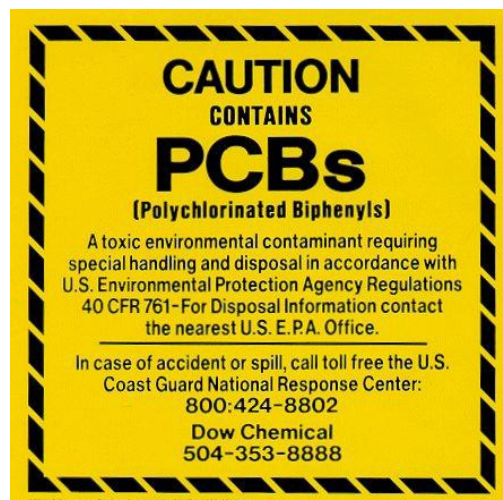

- 23.3 Owners are specifically responsible for properly handling any equipment containing PCBs. For example, PCB transformers must meet the following requirements:
- 23.3.1 PCB transformers and owners must be registered with the local Fire Department.
 - 23.3.2 The PCB transformer and access to the PCB transformer (fences, doors, etc.) must be plainly marked with a PCB label.
 - 23.3.3 Combustible materials may not be stored within five meters of a PCB transformer or enclosure.
 - 23.3.4 If a transformer is involved in a fire-related incident, the National Response Center must be notified.
 - 23.3.5 Radial PCB transformers must be equipped with high current fault protection. Units with secondary voltage of 480 volts or greater must be equipped with low current fault protection.
- 23.4 The Texas Commission on Environmental Quality (TCEQ) considers PCBs to be special waste. Contact Environmental Health & Safety for disposal procedures.
- 23.5 **IMPORTANT:** Report all PCB leaks (e.g., transformer leaks) to the Environmental Health & Safety immediately.

24.0 Preventing Slips and Falls

- 24.1 It is easy to prevent falling accidents. Employees should always follow good housekeeping practices and pay attention to their environment to avoid slips and falls.
- 24.2 In addition, employees should follow these guidelines:
- 24.2.1 Turn on office lights. Ensure that passageways are adequately lit.
 - 24.2.2 Avoid horseplay.
 - 24.2.3 Avoid unnecessary haste. Do not run in work areas.
 - 24.2.4 Use ladders or step-stools to reach high places. Never climb onto chairs, tables, drawers, or shelves.
 - 24.2.5 Keep hallways and stairwells neat and free of obstacles.
 - 24.2.6 Remove items that may pose a potential slipping hazard.
 - 24.2.7 Clean up spills as soon as they occur.
 - 24.2.8 Never obstruct your view when walking.
 - 24.2.9 Do not wear clothing that is too long or shoes that have slippery heels or soles.
 - 24.2.10 Hold the handrail when using stairs.
 - 24.2.11 Be careful when walking on wet surfaces or when entering a building while wearing wet shoes.



24.2.12 Report uneven surfaces, such as loose or missing floor tiles, to the Physical Plant for repair.

24.2.13 Wear the proper Person Protective Equipment on your feet when working in, around or on slippery/slick surfaces.

25.0 Smoking

25.1 The United States Surgeon General and the Environmental Protection Agency have determined the following:

25.1.1 Breathing secondary smoke causes various diseases and allergic reactions in healthy non-smokers.

25.1.2 Separating smokers and non-smokers within the same air space does not eliminate exposure to environmental tobacco smoke for non-smokers.

25.1.3 Tobacco smoke and secondary tobacco smoke are Class A carcinogens.



25.2 To promote a safe, healthy, and pleasant environment for employees, students, and visitors, TAMIU has instituted a smoke-free policy ([University Rule 34.05.99.](#))

25.3 **SMOKING POLICY:** All University facilities, buildings, and vehicles, regardless of location or ownership, must be entirely smoke-free. This includes all foyers, entryways, classrooms, restrooms, offices, athletic facilities (indoor and outdoor), eating areas, and university-owned/leased housing.

26.0 Visitor Safety

26.1 Employees must take special care to ensure visitor safety. This is particularly important when bringing visitors to potentially hazardous areas such as construction sites or laboratories.

26.2 **IMPORTANT:** Office visitors should be escorted; worksite visitors should be escorted, supervised, and monitored. Do not bring children to the workplace.

26.3 If a visitor is injured, be sure to report the occurrence to Environmental Health & Safety after attending to the injury.



END OF SECTION

III. OFFICE SAFETY

1.0 General Office Safety

1.1 A large percentage of workplace accidents and injuries occur in office buildings. Like the shop or laboratory, the office requires a few preventive measures to ensure a safe and healthy environment. Common causes of office accidents include the following:

- 1.1.1 Slipping, tripping, and falling hazards
- 1.1.2 Burning, cutting, and pinching hazards
- 1.1.3 Improper lifting and handling techniques
- 1.1.4 Unobservant and inattentive employees
- 1.1.5 Improper office layout and arrangement
- 1.1.6 Dangerous electrical wiring
- 1.1.7 Exposure to toxic substances
- 1.1.8 Horseplay



- 1.2 The following sections address several office safety practices. Other preventive measures not mentioned here may also be necessary.
- 1.3 **REMEMBER:** *The office building is not a sterile working environment; common workplace hazards can be dangerous when you ignore them.*
- 1.4 Refer to other chapters in this manual, such as Electrical Safety, General Safety, Fire Safety, and others for more information on workplace safety. Always use common sense when safety is a concern.

2.0 Good Housekeeping Practices

2.1 Many office accidents are caused by poor housekeeping practices. By keeping the office floor both neat and clean, you can eliminate most slipping, tripping, and falling hazards. Other good housekeeping practices include the following:



- 2.1.1 Ensure that office lighting is adequate and available. Replace burned out light bulbs, and have additional lighting installed, as necessary.
- 2.1.2 Ensure that electrical cords and phone cords do not cross walkways or otherwise pose a tripping hazard. If you cannot move a cord, have a new outlet installed or secure the cord to the floor with cord covering strips. Do not tape cords down as a long-term solution or run them underneath carpet.

- 2.1.3 Report or repair tripping hazards such as defective tiles, boards, or carpet immediately.
- 2.1.4 Clean spills and pick up fallen debris immediately. Even a loose pencil or paper clip could cause a serious falling injury.
- 2.1.5 Keep office equipment, facilities, and machines in good condition.
- 2.1.6 Store items in an approved storage space. Take care to not stack boxes too high or too tight. Ensure that boxes are clearly labeled with their contents.

3.0 Hazardous Objects and Materials

3.1 Hazardous objects such as firearms are not permitted in the workplace. In addition, hazardous chemicals and materials should not be stored in the general office. Hazardous materials include, but are not limited to, the following:

- 3.1.1 Carcinogens
- 3.1.2 Combustibles
- 3.1.3 Flammables
- 3.1.4 Gas cylinders
- 3.1.5 Irritants
- 3.1.6 Oxidizers
- 3.1.7 Reactives



4.0 Preventing Cuts and Punctures



4.1 Cuts and punctures happen when people use everyday office supplies without exercising care. Follow these guidelines to help reduce the chance for cuts and punctures:

- 4.1.1 When sealing envelopes, use a liquid dispenser, not your tongue.
- 4.1.2 Be careful when using kitchen knives, scissors, staplers, letter openers, paper cutters and box openers. Any of these items could cause a painful injury.
- 4.1.3 Avoid picking up broken glass with your bare hands. Wear gloves and use a broom and a dust pan.
- 4.1.4 Place used blades or broken glass in a rigid container, such as a box, before disposing in a wastebasket.



5.0 Preventing Machine Accidents

5.1 Only use machines that you know how to operate. Never attempt to operate an unfamiliar machine without reading the machine instructions or receiving



directions from a qualified employee. In addition, follow these guidelines to ensure machine safety:

- 5.1.1 Secure machines that tend to move during operation.
 - 5.1.2 Do not place machines near the edge of a table or desk.
 - 5.1.3 Ensure that machines with moving parts are guarded to prevent accidents. Do not remove these guards.
 - 5.1.4 Unplug defective machines and have them repaired immediately.
 - 5.1.5 Do not use any machine that smokes, sparks, shocks, or appears defective in any way.
 - 5.1.6 Close hand-operated paper cutters after each use and activate the guard.
 - 5.1.7 Take care when working with copy machines. If you have to open the machine for maintenance, repair, or troubleshooting, remember that some parts may be hot. Always follow the manufacturer's instructions for troubleshooting.
 - 5.1.8 Unplug paper shredders before conducting maintenance, repair, or troubleshooting.
- 5.2 Some items can be very dangerous when worn around machinery with moving parts. Avoid wearing the following items around machines within unguarded moving parts:

- 5.2.1 Loose belts
- 5.2.2 Jewelry
- 5.2.3 Long, loose hair
- 5.2.4 Long, loose sleeves or pants
- 5.2.5 Scarves
- 5.2.6 Ties



6.0 Preventing Slips and Falls

- 6.1 As outlined in the General Safety chapter of this manual, the easiest way to avoid slips and falls is to pay attention to your surroundings and to avoid running or rushing. To ensure safety for others in the office, however, follow these guidelines:

- 6.1.1 Arrange office furnishings in a manner that provides unobstructed areas for movement.
- 6.1.2 Keep stairs, steps, flooring, and carpeting well maintained.
- 6.1.3 Ensure that glass doors have some type of marking to keep people from walking through them.
- 6.1.4 Clearly mark any difference in floor level



that could cause an accident.

- 6.1.5 Secure throw rugs and mats to prevent slipping hazards.
- 6.1.6 Do not place wastebaskets or other objects in walkways.
- 6.1.7 Always pay attention and be aware of your surroundings

7.0 Preventing Stress

- 7.1 To reduce stress and prevent fatigue, it is important to take mini-breaks (not many breaks) throughout the day. If possible, change tasks at least once every two hours. Stretch your arms, neck, and legs often if you do the same type of work for long periods of time. Tip for healthy eyes use the 20-20-20 rule. Every 20 minutes look away from your monitor, and stare at something 20 feet away for 20 seconds. For a quick pick-me-up, breathe deeply several times by inhaling through your nose and exhaling through your mouth. In addition, always try to eat your lunch somewhere other than your desk.



- 7.2 Other examples of stress-relieving exercises that can be done at your desk include the following:
- 7.2.1 Head and Neck Stretch: Slowly turn your head to the left, and hold it for three seconds. Slowly turn your head to the right, and hold it for three seconds. Drop your chin gently towards your chest, and then tilt it back as far as you can. Repeat these steps five to ten times.
 - 7.2.2 Shoulder Roll: Roll your shoulders forward and then backward using a circular motion. Repeat in each direction five to ten times.
 - 7.2.3 Upper Back Stretch: Grasp one arm below the elbow and pull gently towards the other shoulder. Hold this position for five seconds and then repeat with the other arm.
 - 7.2.4 Wrist Wave: With your arms extended in front of you, raise and lower your hands several times.
 - 7.2.5 Finger Stretch: Make fists with your hands and hold tight for one second, then spread your fingers wide for five seconds

8.0 Equipment and Furniture Safety

- 8.1 As mentioned earlier, common office machines, such as the following, require special safety consideration: copiers, microwaves, adding machines, typewriters, and computers. If there is ever any question of how to properly use a piece of equipment or furniture, always refer to the manufacturer's guidelines for further instruction. If you notice a piece of equipment is damaged or working

improperly, un-plug the machine, do not use the damaged equipment, and refer to manufacturer's guidelines. All equipment should only be repaired by a certified repairperson.

8.1.1 Other office equipment that requires safety consideration includes furniture such as file cabinets and shelves, desks, and chairs.

8.2 File Cabinets and Shelves

8.2.1 Because file cabinets and shelves tend to support heavy loads, treat them with special care.



8.2.2 Follow these safety guidelines for file cabinets:

8.2.2.1 Secure file cabinets that are not weighted at the bottom. Either attaches them to the floor or to the wall.

8.2.2.2 Ensure that file cabinet drawers cannot easily be pulled clear of the cabinet.

8.2.2.3 Do not block ventilation grates with file cabinets.

8.2.2.4 Open only one drawer at a time to keep the cabinet from toppling.

8.2.2.5 Close drawers when they are not in use.

8.2.2.6 Do not place heavy objects on top of cabinets. Be aware that anything on top of a cabinet may fall off if a drawer is opened suddenly.

8.2.2.7 Close drawers slowly using the handle to avoid pinched fingers.

8.2.2.8 Keep the bottom drawer full. This will help stabilize the entire cabinet.

8.2.3 In addition, follow these safety guidelines for office shelves:

8.2.3.1 Secure shelves by attaching them to the floor or wall.

8.2.3.2 Place heavy objects on the bottom shelves. This will keep the entire structure more stable.

8.2.3.3 Ensure that there is at least 18 inches between the top shelf items and the ceiling. This space will allow ceiling sprinklers (if present) to function properly if a fire occurs.

8.2.3.4 Do not block ventilation grates with shelves.

8.2.3.5 Never climb on shelves (even lower shelves). Use an approved ladder.

8.3 Desks

8.3.1 Follow these safety guidelines for office desks:

8.3.1.1 Keep desks in good condition (i.e., free from sharp edges, nails, etc.).

8.3.1.2 Ensure that desks do not block exits or passageways.

8.3.1.3 Ensure that glass-top desks do not have sharp edges.

8.3.1.4 Ensure that desks with spring-loaded tables function properly. The table should not spring forth with enough force to cause an injury.

8.3.1.5 Do not climb on desks. Use an approved ladder.

8.3.1.6 Keep desk drawers closed when not in use.

8.3.1.7 Repair or report any desk damage that could be hazardous.



8.4 Chairs

8.4.1 Safety guidelines for office chairs include the following:

8.4.1.1 Do not lean back in office chairs, particularly swivel chairs with rollers.

8.4.1.2 Do not climb on any office chair. Use an approved ladder.

8.4.1.3 Office desk chairs should have adjustable back supports and seat height. Make sure that your chair's back support position and seat height are comfortable.

8.4.1.4 Take care when sitting in a chair with rollers. Make sure it does not roll out from under you when you sit down.

8.4.1.5 Repair or report any chair damage that could be hazardous.

8.4.1.6 Do not roll chairs over electrical cords.



8.5 Ladders and Stepstools

8.5.1 Always use an approved ladder or stool to reach any item above your extended arm height. Never use a makeshift device, such as a chair, desktop, file cabinet, bookshelf, or box, as a substitute for a ladder.



8.5.2 Follow these guidelines when using ladders:

8.5.2.1 Do not load a ladder above its intended weight capacity.

8.5.2.2 Place ladders on slip-free surfaces even if they have slip-resistant feet. Secure the ladder if a slip-free surface is not available.

8.5.2.3 Avoid placing ladders in walkways. Secure a ladder if its location could cause an accident.

8.5.2.4 Keep areas around ladders clean and free of debris.

8.5.2.5 Do not use a ladder in front of a door unless the door is locked and barricaded.

8.5.2.6 Refer to the Shop Safety chapter in this manual for more information on ladder safety.

9.0 Work Station Arrangement

9.1 With the extensive use of computers and other automated desk devices in the workplace, employees must take special care to ensure proper work station arrangement. For the purpose of this manual, a work station consists of the equipment and furniture associated with a typical desk job (i.e., desk, chair, and computer components).



9.2 In recent years, computer screens or Video Display Terminals (VDTs) have received much attention concerning non-ionizing radiation levels. Tests prove, however, that VDTs do not emit harmful levels of radiation. Improper work station arrangement combined with repetitive motion, however, may contribute to visual and musculoskeletal fatigue.

9.3 Cumulative trauma disorders, such as carpal tunnel syndrome may result from the stress of repetitive motion. Therefore, it is very important to arrange your work station properly and to take breaks frequently.

9.4 Ergonomic surveys/reviews of the work station arrangement can be requested from Environmental Health and Safety.

10.0 Operator's Position

10.1 Your seating position at work is important to your comfort and safety. To reduce the painful effects of repetitive motion, follow these guidelines when working with computers or typewriters:



- 10.1.1 Always sit up straight. Make sure your chair is adjusted to provide adequate support to your back.
- 10.1.2 Place your feet flat on the floor or on a footrest. Lower legs should be approximately vertical, and thighs should be approximately horizontal. The majority of your weight should be on the buttocks.
- 10.1.3 Ensure that there is at least 1 inch of clearance between the top of your thighs and the bottom of the desk or table.
- 10.1.4 Keep your wrists in a natural position. They should not rest on the edge of the desk.
- 10.1.5 Keep the front edge of your chair approximately 4 inches behind your knees.

11.0 Equipment Arrangement

- 11.1 By properly arranging your equipment, you can also help reduce the harmful effects of repetitive motion. Follow these guidelines for arranging office equipment:



- 11.1.1 Lighting: Lighting around computer work stations should illuminate the work area without obscuring the VDT or causing glare. Position computer screens, draperies, blinds, and pictures to reduce glare during work hours (e.g., place the VDT screen at a right angle to the window).

- 11.1.2 VDT Screen: VDT images should be clear and well-defined. Adjust the screen's brightness, contrast and display size to meet your needs. If a screen flickers or jumps, have it repaired or replaced. Place the VDT 20-28 inches away from your face. The center of the VDT should be approximately 15 to 25 degrees below your line of vision.



- 11.1.3 Keyboards: Position computer keyboards so that the angle between the forearm and upper arm is between 80 and 120 degrees. Place the keyboard in an area that is accessible and comfortable.



- 11.1.4 Wrist Support: Use wrist supports made of padded material. The support should allow you to type without bending your wrists.

- 11.1.5 Document Holders: Keep documents at approximately the same height and distance from your face as the VDT screen.



- 11.1.6 Telephones: Neck tension is a common problem caused by holding the telephone between the head and neck. Use a headset or speakerphone if you use the telephone for extended periods of time.

- 11.2 Contact Environmental Health and Safety if you have any questions regarding your work station arrangement. If you develop pain that you believe arises from work you do at the office, please contact your supervisor.

END OF SECTION

IV. SHOP SAFETY

1.0 General Shop Safety

1.1 The hazards associated with shop work require special safety considerations. Whether you work in a metal shop, wood shop, automotive shop, glass shop, or electrical shop, the potential hazards for personal injury are numerous. This chapter highlights essential safety information for working in a TAMIU shop. Refer to other chapters in this manual, including General Safety, Electrical Safety, and Fire/Life Safety, for more information on handling many shop situations. The following table highlights common shop hazards:



Potential Hazards	Hazard Sources
Physical: - Compressed air/gases - Flying debris - Noise - Pinching, cutting, amputation - Slipping, tripping - UV radiation	- Oxygen, acetylene, air - Grinders, saws, welders - Any power tool - Vises, power tools, hand tools - Wood/metal chips, electrical cords, oil, etc. - Welding
Electrical: - Overload - Fire - Shock	- Too many cords per outlet - Frayed, damaged cords - Ungrounded tools, equipment
Fire: - Flammable chemicals - Sparks - Static sparks - Uncontrolled fire	- Gasoline, degreasers, paint thinners, etc. - Welders, grinders - Ungrounded tools or solvent containers - Lack of appropriate fire extinguishers
Chemical: - Toxic liquids - Toxic fumes, gases, dusts	- Cleaning solvents, degreasers, etc. - Welding, motor exhaust, etc.

1.2 It is not possible to detail all the risks involved with shop work. However, it is possible to foresee many hazards by carefully planning each job. To prevent accidents, utilize your knowledge, training, and common sense. Evaluate potential sources of injury, and attempt to eliminate any hazards.

2.0 Personal Protection

2.1 There are several measures you must take to protect yourself from shop hazards. For example, do not wear the following when working around machinery:

- 2.1.1 Loose fitting clothing
- 2.1.2 Neckties
- 2.1.3 Jewelry
- 2.1.4 Long loose hair



If you must wear a long sleeved shirt, be sure the sleeves are rolled down and buttoned. Snug fitting clothes and closed toe shoes are essential safety equipment in the shop.

- 2.2 Always wear safety glasses with side shields when working with shop equipment. Anytime there is question regarding required wardrobe for personal protection, refer to respective departmental requirements. Additional protection using goggles or face shields may be necessary for the following types of work:

- 2.2.1 Grinding, Chipping, Sandblasting
- 2.2.2 Welding
- 2.2.3 Glass working



- 2.3 Wear approved hard hats whenever there is a chance of objects falling from above. In addition, wear suitable gloves for the job at hand when working with the following:

- 2.3.1 Scrap metal or wood
- 2.3.2 Sharp-edged stock
- 2.3.3 Unfinished lumber



For glove selection and requirement assistance contact Environmental Health and Safety.

- 2.4 Refer to the Personal Protective Equipment chapter in this manual for more information.

3.0 Job Safety

- 3.1 Before beginning work in a shop, be sure you are authorized to perform the work to be done and inspect your tools and equipment. If a procedure is potentially hazardous to others in the area, warn fellow workers accordingly. Use warning signs or barriers, as necessary.



- 3.2 Notify your supervisor if you notice any unsafe conditions such as the following:
 - 3.2.1 Defective tools or equipment
 - 3.2.2 Improperly guarded machines
 - 3.2.3 Oil, gas, or other leaks

- 3.2.4 Any other condition that you feel may jeopardize you or your co-worker's safety
- 3.3 Inform other employees if you see an unsafe work practice; however, be careful not to distract a person who is working with power tools.

4.0 Safety Guidelines

- 4.1 Follow these guidelines for general shop safety:
 - 4.1.1 Know the hazards associated with your work. Be sure you are fully educated on the proper use and operation of any tool before beginning a job.
 - 4.1.2 Always wear appropriate safety gear and protective clothing.
 - 4.1.3 Wear nitrile gloves when cleaning with degreasers or ferric chloride.
 - 4.1.4 Ensure that there is adequate ventilation to prevent exposure from vapors of glues, lacquers, paints and from dust and fumes.
 - 4.1.5 Maintain good housekeeping standards.
 - 4.1.6 Keep the work area free from slipping/tripping hazards (oil, cords, debris, etc.).
 - 4.1.7 Clean all spills immediately.
 - 4.1.8 Remove sawdust, wood chips, and metal chips regularly.
 - 4.1.9 It is recommended that electrical cords pull down from an overhead pulley rather than lying on the floor.
 - 4.1.10 All containers must be labeled with its contents.
 - 4.1.11 Leave tool and equipment guards in place.
 - 4.1.12 Leave in place and utilize all shielding on tools and equipment.
 - 4.1.13 Know where fire extinguishers are located and how to use them.
 - 4.1.14 Make sure all tools and equipment are properly grounded and that cords are in good condition.
 - 4.1.15 Double-insulated tools or those with three-wire cords are essential for safety.
 - 4.1.16 Use extension cords that are large enough for the load and distance.
 - 4.1.17 Secure all compressed gas cylinders. Never use compressed gas to clean clothing or skin.
 - 4.1.18 Always use flashback arrestors on cutting/welding torches.
 - 4.1.19 Take precautions against heat stroke and heat exhaustion.
 - 4.1.20 Wear infrared safety goggles when appropriate, e.g. when operating brazing or cutting torch.
- 4.2 Environmental Health & Safety periodically inspects all TAMIU shops. See the EHSD Shop Audit Checklist for questions regarding inspection criteria and what



is being looked for during the shop inspections. Refer any questions regarding shop safety to the Environmental Health & Safety.

5.0 Hand Tools

5.1 Hand tools are non-powered tools. They include axes, wrenches, hammers, chisels, screw drivers, and other hand-operated mechanisms. Even though hand tool injuries tend to be less severe than power tool injuries, hand tool injuries are more common. Because people take everyday hand tools for granted, they forget to follow simple precautions for safety. The most common hand tool accidents are caused by the following:

- 5.1.1 Failure to use the right tool
- 5.1.2 Failure to use a tool correctly
- 5.1.3 Failure to keep edged tools sharp
- 5.1.4 Failure to replace or repair a defective tool
- 5.1.5 Failure to store tools safely



IMPORTANT: Use the right tool to complete a job safely, quickly, and efficiently.

5.2 Follow these guidelines for general hand tool safety:

- 5.2.1 Wear safety glasses whenever you hammer or cut, especially when working with surfaces that chip or splinter.
- 5.2.2 Do not use a screwdriver as a chisel.
- 5.2.3 Do not use a chisel as a screwdriver.
- 5.2.4 Do not use a knife as a screwdriver.
- 5.2.5 Never carry a screwdriver or chisel in your pocket. If you fall, the tool could cause a serious injury. Instead, use a tool belt holder or tool box.
- 5.2.6 Replace loose, splintered, or cracked handles. Loose hammer, axe, or maul heads can fly off defective handles.
- 5.2.7 Use the proper wrench to tighten or loosen nuts.
- 5.2.8 When using a chisel, always chip or cut away from yourself. Use a soft-headed hammer or mallet to strike a wooden chisel handle. A metal hammer or mallet may cause the handle to split.
- 5.2.9 Do not use a wrench if the jaws are sprung.
- 5.2.10 Do not use impact tools, such as chisels, wedges, or drift pins, if their heads are mushroom shaped. The heads may shatter upon impact.
- 5.2.11 Direct saw blades, knives, and other tools away from aisle areas and other employees.
- 5.2.12 Keep knives and scissors sharp. Dull tools are more dangerous than sharp tools.



5.2.13 Iron or steel hand tools may cause sparks and be hazardous around flammable substances. Use spark-resistant tools made from brass, plastic, aluminum, or wood when working around flammable hazards.

5.3 Improper tool storage is responsible for many shop accidents. Follow these guidelines to ensure proper tool storage:

5.3.1 Have a specific place for each tool.

5.3.2 Do not place unguarded cutting tools in a drawer. Many hand injuries are caused by rummaging through drawers that contain a jumbled assortment of sharp-edged tools.

5.3.3 Store knives or chisels in their scabbards.

5.3.4 Hang saws with the blades away from someone's reach.

5.3.5 Provide sturdy hooks to hang most tools on.

5.3.6 Rack heavy tools, such as axes and sledges, with the heavy end down.

6.0 Insulation

6.1 Asbestos, fiberglass, man-made mineral fibers, PVC, and urethane foam can be extreme respiratory hazards. To protect yourself from these and other respiratory hazards, minimize your exposure to particulate matter from insulation, fumes, dusts, and aerosols. Refer to the General Safety chapter for more information on asbestos.



7.0 Ladders

Refer this section to Construction Safety, Fall Protection/Ladders



8.0 Power Tools

8.1 Power tools can be extremely dangerous if they are used improperly. Each year, thousands of people are injured or killed by power tool accidents. Common accidents associated with power tools include abrasions, cuts, lacerations, amputations, burns, electrocution, and broken bones. These accidents are often caused by the following:

8.1.1 Touching the cutting, drilling, or grinding components

8.1.2 Getting caught in moving parts

8.1.3 Suffering electrical shock due to improper grounding, equipment defects, or operator misuse

8.1.4 Being struck by particles that normally eject during operation

8.1.5 Touching hot tools or work pieces

8.1.6 Falling in the work area

8.1.7 Being struck by falling tools



8.2 When working around power tools, you must wear personal protective equipment and avoid wearing loose clothing or jewelry that could catch in moving machinery. In addition to general shop guidelines, follow these guidelines for working with power tools:

8.2.1 Use the correct tool for the job. Do not use a tool or attachment for something it was not designed to do.

8.2.2 Select the correct bit, blade, cutter, or grinder wheel for the material at hand. This precaution will reduce the chance for an accident and improve the quality of your work.



8.2.3 Keep all guards in place. Cover exposed belts, pulleys, gears, and shafts that could cause injury.

8.2.4 Always operate tools at the correct speed for the job at hand. Working too slowly can cause an accident just as easily as working too fast.

8.2.5 Watch your work when operating power tools. Stop working if something distracts you.

8.2.6 Do not rely on strength to perform an operation. The correct tool, blade, and method should not require excessive strength. If undue force is necessary, you may be using the wrong tool or have a dull blade.



8.2.7 Before clearing jams or blockages on power tools, disconnect from power source. Do not use your hand to clear jams or blockages, use an appropriate tool.

8.2.8 Never reach over equipment while it is running.

8.2.9 Never disable or tamper with safety releases or other automatic switches.

8.2.10 When the chance for operator injury is great, use a push stick to move material through a machine.

8.2.11 Disconnect power tools before performing maintenance or changing components.

8.2.12 Keep a firm grip on portable power tools. These tools tend to "get away" from operators and can be difficult to control.

8.2.13 Remove chuck keys or adjusting tools prior to operation.

8.2.14 Keep bystanders away from moving machinery.

8.2.15 Do not operate power tools when you are sick, fatigued, or taking strong medication.

8.2.16 When possible, secure work pieces with a clamp or vise to free the hands and minimize the chance of injury. Use a jig for pieces that are unstable or do not lie flat.

8.2.17 Inspect wiring and mechanisms before operating.

8.2.18 All machinery repairs must be completed by a certified repair person.

9.0 Guards

9.1 Moving machine parts must be safeguarded to protect operators from serious injury. Belts, gears, shafts, pulleys, fly wheels, chains, and other moving parts must be guarded if there is a chance they could injure an employee.

9.1.1 Hazardous areas that must be guarded include the following:

9.1.2 Point of operation

9.1.3 Area where the machine either cuts, bends, molds, or forms, the material

9.2 Pinch/nip point: Area where moving machine parts can trap, pinch, or crush body parts (e.g., roller feeds, intermeshing gears, etc.).



9.3 Sharp edges

9.4 Stored potential energy

9.5 There are three types of barrier guards that protect people from moving machinery. They consist of the following:

9.5.1 Fixed guards

9.5.2 Interlocked guards

9.5.3 Adjustable guards



9.6 A fixed guard is a permanent machine part that completely encases potential hazards. Fixed guards provide maximum operator protection. Interlock guards are connected to a machine's power source. If the guard is opened or removed, the machine automatically disengages. Interlocking guards are often preferable because they provide adequate protection to the operator, but they also allow easy machine maintenance. This is ideal for problems such as jams.

9.7 Self-adjusting guards change their position to allow materials to pass through the moving components of a power tool. These guards accommodate various types of materials, but they provide less protection to the operator.

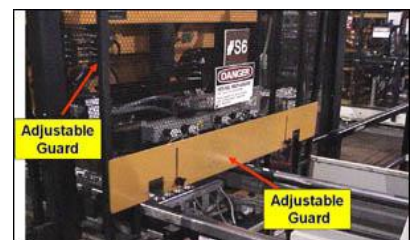

IMPORTANT: Guards must be in place. If a guard is removed to perform maintenance or repairs, follow lockout/tagout procedures. Replace the guard after repairs are completed. Do not disable or move machine guards for any reason. If you notice that a guard is missing or damaged, contact your supervisor and have the guard replaced or repaired before beginning work.

NOTE: Hand-held power tools typically have less guarding in place than stationary power tools. Use extreme caution when working with hand-held power tools and always wear a face shield.

10.0 Safety Guidelines

10.1 In addition to the safety suggestions for general power tool usage, there are specific safety requirements for each type of tool. The following sections cover safety guidelines for these types of tools:

- 10.1.1 Drill press
- 10.1.2 Grinder
- 10.1.3 Jointer and shaper
- 10.1.4 Lathe
- 10.1.5 Nail/air gun
- 10.1.6 Planer
- 10.1.7 Forging machines
- 10.1.8 Sander
- 10.1.9 Saw
- 10.1.10 Band
- 10.1.11 Circular
- 10.1.12 Radial arm
- 10.1.13 Table
- 10.1.14 Compound miter saw
- 10.1.15 Router
- 10.1.16 Reciprocal saw
- 10.1.17 Dremel tool

11.1 Drill Press Safety

11.1 Follow these safety guidelines when using drill presses:

- 11.1.1 Securely fasten work materials to prevent spinning. Never use your hands to secure work materials.
- 11.1.2 Use a center punch to score the material before drilling.
- 11.1.3 Run the drill at the correct speed. Forcing or feeding too fast can break drill bits.
- 11.1.4 Never attempt to loosen the chuck unless the power is off.
- 11.1.5 Lower the spindle before removing a chuck.
- 11.1.6 Never use a regular auger bit in a drill press.
- 11.1.7 Frequently back the drill out of deep cuts to clean and cool the bit.



12.0 Grinder Safety

12.1 Follow these safety guidelines when working with grinders:

- 12.1.1 Ensure that no combustible or flammable materials are nearby that could be ignited by sparks from the grinder wheel.
- 12.1.2 Ensure that a guard covers at least 270 degrees of the grinding wheel on bench-mounted machines.
- 12.1.3 Place the grinder tool rest 1/8 inch from the wheel and slightly above the center line.
- 12.1.4 Allow the grinder to reach full speed before stepping into the grinding position. Faulty wheels usually break at the start of an operation.
- 12.1.5 Unless otherwise designed, grind on the face of the wheel.
- 12.1.6 Use a vise-grip plier or clamp to hold small pieces.
- 12.1.7 Slowly move work pieces across the face of wheel in a uniform manner. This will keep the wheel sound.
- 12.1.8 Do not grind non-ferrous materials.
- 12.1.9 Periodically check grinder wheels for soundness. Suspend the wheel on a string and tap it. If the wheel rings, it is probably sound.
- 12.1.10 Replace wheels that are badly worn or cracked.
- 12.1.11 Never use a wheel that has been dropped or received a heavy blow, even if there is no apparent damage.
- 12.1.12 Before using a new wheel, let it run a few seconds at full speed to make sure it is balanced.



13.0 Hot Work Permit

13.1 Refer to Hot Work Permitting through Environmental Health and Safety. The following is an example of a Hot Work Permit:

HOT WORK PERMIT
Hot work is any operation that generates heat, spark or open flame. This includes, but is not necessarily limited to welding, cutting, grinding, soldering, torch applied roofing, heat gun use and similar activities. Before initiating Hot Work, determine if there is a safer way to complete the work.
Date: _____ Location: _____ Job # _____
Type of Hot Work: <input type="checkbox"/> Soldering <input type="checkbox"/> Welding <input type="checkbox"/> Cutting <input type="checkbox"/> Roofing <input type="checkbox"/> Other _____
Hot Work Precautions Check List: Complete prior to any hot work beginning in an area not designated for hot work. Check each box where the statement is true. If

any statements are not true, then hot work should not begin until that issue has been safely resolved.

Required Safety Precautions

- Fire suppression sprinklers, fire hoses or fire extinguishers are available and operable.
- Hot work equipment is operable and in good repair.
- Smoke / fire detectors in the immediate area of the hot work have been temporarily disabled until the hot work is complete.
- Building occupants have been protected or isolated from the hot work area.
- Drums, barrels and tanks have been cleaned and purged of flammables and toxics, all tank feeds are closed, and the tank is vented. Requirements within 35 feet:
 - Area within 35 feet of the work area has been properly swept to remove any combustible debris.
 - Flammable and ignitable materials and debris have been moved at least 35 feet from the hot work area or covered and protected with fire resistant materials.
 - Cracks or holes in floors, walls and ceilings (including ductwork) are covered or plugged
 - Combustible floors covered with fire-resistive material

Requirements within 50 feet:

- Explosives, compressed gas cylinders or stored fuel have been moved at least 50 feet from the hot work area or have been protected from the hot work. Work on walls or Ceilings
- Construction is noncombustible and has no combustible covering or insulation.
- Areas adjacent to walls being worked on are checked for combustibles and any combustibles are either removed or protected. Fire Watch required during Hot Work and a minimum of 30 minutes following completion of work.

Yes _____ No _____ Name: _____

A fire watch is needed for all hot work activities unless the hot work area has no fire hazards or combustible exposures. The fire watch must have fire-extinguishing equipment readily available and be trained in its use. They must also be familiar with the procedures for sounding an alarm in the event of a fire. The fire watch will watch for fires in the exposed areas and are responsible for extinguishing spot fires and communicating alarms immediately. The fire watch may be assigned other work duties while in the hot work area; however they need to be vigilant in watching for fires.

When work is completed:

- Inspect work area, and any potentially affected surrounding areas, for fire, fire damage, or potential for fire.
- Reactivated smoke/fire detectors that were disabled because of the hot work.

I verify that the above location has been examined and the necessary precautions have been taken to prevent the outbreak of fire due to Hot Work.

Employee Signature (Issued): _____ Date: _____ Time: _____

Employee Signature (Closed): _____ Date: _____ Time: _____

Supervisor Signature: _____ Date: _____

This Permit is valid only for the day issued

14.0 Jointer and Shaper Safety

14.1 Follow these safety guidelines when using jointers and shapers:



- 14.1.1 Ensure that jointers are equipped with cylindrical cutting heads.
- 14.1.2 Use a push stick, as necessary.
- 14.1.3 Do not use single cutter knives in shaper heads.
- 14.1.4 Ensure that knives are balanced and correctly mounted.
- 14.1.5 Adjust cut depth before turning the machine on.
- 14.1.6 Do not use the jointer for strips that are less than 1 inch wide.

15.0 Lathe Safety

15.1 Follow these safety guidelines when working with wood lathes:



- 15.1.1 Examine wood for knots and other defects before placing it in the lathe. Use caution when working with wood that has knots.
- 15.1.2 Ensure that glued materials are set before placing them in the lathe.
- 15.1.3 Before turning the lathe on, slowly turn rough materials a few times to ensure they will clear the tool rest.
- 15.1.4 Keep hands off the chuck rim when the lathe is moving.
- 15.1.5 Hold all wood cutting tools firmly with two hands.
- 15.1.6 Start all jobs at the lowest speed. Ensure that materials are in a cylindrical form before advancing to higher speeds. Never turn large diameter materials at a high speed.
- 15.1.7 Firmly screw faceplate work to the faceplate. Take care to avoid cutting too deep and hitting the screws.
- 15.1.8 Do not cut too deep or scrape too long.
- 15.1.9 Remove the "T" rest when sanding or polishing.

15.2 Follow these safety guidelines when working with metal lathes:

- 15.2.1 Make sure that all gear and belt guards are in place.
- 15.2.2 Never leave a chuck wrench in a chuck.
- 15.2.3 Keep your hands off chuck rims when a lathe is in operation.
- 15.2.4 Do not attempt to screw the chuck onto the lathe spindle with the power on, as it may get cross-threaded and cause injury. Stop the machine, place a board under the chuck, and then screw on by hand.
- 15.2.5 Steady rests should be properly adjusted to conform to the material being worked on.
- 15.2.6 When filing work in a lathe, always face the head stock and chuck.
- 15.2.7 See that tailstock, tool holder, and work are properly clamped before turning on power.
- 15.2.8 Never attempt to adjust a tool while the lathe is running.
- 15.2.9 Never apply a wrench to revolving work or parts.
- 15.2.10 Always use a brush to remove chips; never your hands.
- 15.2.11 When possible, use pipe sleeves to cover work protruding from the end of the lathe.
- 15.2.12 Before removing your work from the lathe, remove the tool bit.



16.0 Nail/Air Gun Safety (Pneumatic Fastening Tools)

- 16.1 Nail guns and air guns are powered by compressed air. The main danger associated with pneumatic fastening tools is injury from one of the tool's attachments or fasteners.
- 16.2 Follow these safety guidelines for working with pneumatic tools:



- 16.2.1 Ensure that pneumatic tools which shoot nails, rivets, or staples are equipped with a device that keeps fasteners from ejecting unless the muzzle is pressed against a firm surface.
- 16.2.2 Never point a tool at items you do not want to fasten.
- 16.2.3 Keep your finger off the trigger until you are ready to begin work. Most pneumatic tools have a *hair-trigger* that requires little pressure to activate the gun.
- 16.2.4 Treat air hoses with the same care as an electrical cord.
- 16.2.5 Do not drive fasteners into hard, brittle surfaces or areas where the fastener may pass through the material and protrude on the other side.

17.0 Planer Safety

17.1 Follow these safety guidelines for working with planers:

17.1.1 Examine wood for knots and other defects before placing it in the planer.

17.1.2 Do not plane against the grain of the wood.

17.1.3 Let go of the materials as the feeder rolls catch. Do not follow the work with your hands.

17.1.4 Do not run boards that are more than 2 inches shorter than the distance between the in-feed and out-feed rolls.

17.1.5 Use a push stick if a board stops with its end on the in-feed table.

17.1.6 If a board sticks under the cutter head, turn off the machine to keep from burning the cutter knives.



18.0 Forging Machines

18.1 Once punchers, shears, and benders are activated, it is impossible to stop them until the end of a cycle. Use extreme care when working with these tools.

18.2 Inspection and maintenance: All forge shop equipment must be maintained in a condition which will ensure continued safe operation.

18.3 Hammers and presses: All hammers must be positioned or installed in such a manner that they remain on or are anchored to foundations sufficient to support them according to applicable engineering standards.

18.4 Hammers: Die keys and shims must be made from a grade of material that will not unduly crack or splinter.

18.5 Presses: All manually operated valves and switches must be clearly identified and readily accessible.

18.6 Power-driven hammers: Every steam or air hammer must have a safety cylinder head to act as a cushion if the rod should break or pull out of the ram.

18.7 Gravity Hammers: Air-lift hammers must have a safety Cylinder head.

18.8 Forging and trimming presses: When dies are being changed or maintenance is being performed on the press, ensure the following:

18.8.1 The power to the pressure is locked out.



18.8.2 The flywheel is at rest.

18.8.3 The ram is blocked with a material of the appropriate strength.

18.9 Upsetters: All upsetters must be installed so that they remain on their supporting foundations.

19.0 Sander Safety

19.1 Follow these safety guidelines for working with circular and belt sanders:



19.1.1 Ensure that sanding belts are not too tight or too loose. Never operate a sanding disk if the paper is too loose.

19.1.2 Use the correct grade of abrasive material.

19.1.3 Ensure that the distance between a circular sander and the edge of the table is not greater than 1/4 inch.

19.1.4 Do not push materials against sanders with excessive force.

19.1.5 Sand only on the down stroke side of a disk sander.

19.1.6 Do not hold small pieces by hand. Use a jig for pieces that are difficult to hold securely.

20.0 Saw Safety

20.1 There are numerous types of power saws, such as band saws, circular saws, radial arm saws, saber saws, and table saws. Regardless of the type of saw you use, never reach over the sawline to position or guide materials.



20.2 Follow these safety guidelines for working with band saws:

20.2.1 Set the blade evenly with the proper amount of tension.

20.2.2 Keep your hands on either side of the cut line. Never reach across the cut line for any reason.

20.2.3 Do not stand to the right of the band saw.

20.2.4 Be sure the radius of your cutting area is not too small for the saw blade.

20.2.5 If you hear a rhythmic click, check the saw blade for cracks.

20.3 Follow these safety guidelines for working with circular saws:

20.3.1 Do not raise the saw any higher than absolutely necessary.

20.3.2 Fasten a clearance block to the fence when cutting off short pieces.

20.3.3 Never attempt to clear away scraps with your fingers.



- 20.3.4 Do not cut thin tubular materials with a circular saw.
- 20.3.5 Ensure that the fence is not in the cut line of the saw.
- 20.3.6 Take care when working with warped or twisted lumber.

20.4 Follow these guidelines when working with a radial arm saw:

- 20.4.1 Push the saw blade against the stop before turning on the power.
- 20.4.2 Never place one piece of wood on top of another when using this saw. The top piece may kick over.
- 20.4.3 This saw pulls itself into wooden materials. It may be necessary to hold the saw back to prevent it from choking.
- 20.4.4 Never leave the saw hanging over the end of the arm.



20.5 Follow these guidelines when working with table saws:

- 20.5.1 Circular table saws must have a hood over the portion of the saw above the table. The hood must automatically adjust to the thickness of, and remain in contact with, the material being cut.
- 20.5.2 Circular table saws must have a spreader aligned with the blade. The spreader must be spaced no more than 1/2 inch behind the largest blade mounted in the saw. Providing a spreader while grooving, dadoing, or rabbeting is not required.
- 20.5.3 Circular table saws used for ripping must have non-kickback fingers or dogs.
- 20.5.4 Feed rolls and blades of self-feed circular saws must be protected by a hood or guard to prevent the operator's hand from coming in contact with the in-running rolls.

21.0 Spray Paint Booths

21.1 When working with paint or painting equipment, it is important to have adequate ventilation and to avoid flames or other sources of ignition. Because most paints, varnishes, and thinners are flammable, spray paint jobs should be conducted in a well-ventilated enclosure such as a spray paint booth. Spray paint booths minimize toxic vapors and flammable fumes while providing adequate ventilation. Always wear personal protective equipment when working with paint. In addition, clean the booths, filters and



ventilation ducts frequently to avoid heavy accumulations of paint, dust, and pigment.

22.0 Welding and Cutting

22.1 Welding and cutting are two forms of hot work that require special safety considerations. Unless they are done in a designated shop area, welding and cutting are strictly prohibited without proper authorization.



22.2 Before conducting welding or cutting operations, inspect your equipment for the following:

22.2.1 Welding leads must be completely insulated and in good condition.

22.2.2 Check all other cords for frays and damages

22.2.3 Cutting tools must be leak-free and equipped with proper fittings, gauges, regulators, and flashback devices.

22.2.4 Oxygen and acetylene tanks must be secured in a safe place.

22.3 In addition, follow these guidelines for most welding and cutting procedures:

22.3.1 Conduct welding and cutting operations in a designated area free from flammable materials. When welding or cutting is necessary in an undesignated or hazardous area, have someone nearby act as a fire attendant.

22.3.2 Periodically check welding and cutting areas for combustible atmospheres.

22.3.3 Take care to prevent sparks from starting a fire.

22.3.4 Remove unused gas cylinders from the welding and cutting area.

22.3.5 Keep hoses out of doorways and away from other people. A flattened hose can cause a flashback.

22.3.6 Mark hot metal with a sign or other warning when welding or cutting operations are complete.

22.4 Refer to Hot Work Permitting Plan through Environmental Health and Safety.

22.5 The following table provides an overview of welding and cutting hazards:

HAZARD	WELDING PROCESS			
	PAW/PAC Air Carbon Arc Processes	SMAW GTAW GMAW FCAW	SAW	Oxyfuel
Ergonomic	✓	✓	✓	✓
Electric Shock	✓	✓	✓	X
Bright light	✓	✓	(✓)	✓
Ultraviolet radiation	✓	✓	(✓)	X
Toxic fumes and gases	✓	✓	(✓)	✓
Heat, fire and burns	✓	✓	✓	✓
Noise	✓	X	X	X

X indicates no hazards, ✓ indicates hazard present, (✓) indicates hazard present if SAW flux is absent.

23.0 Welding Guidelines

23.1 Proper selection of personal protective equipment is very important when welding; make sure your welding helmet visor is dark enough to provide adequate protection. Wear fireproof apron and gloves. In addition, take care to protect other people from the hazards of welding. For example, use a welding curtain to protect other employees from UV radiation.

23.2 There are three types of welders:

23.2.1 AC welders: These welders are used for standard welding procedures, AC welders are powered by an electrical cord.

23.2.2 DC welders: These are portable welders that are commonly used in manholes. DC welders have their own power supply.

23.2.3 Wire-feed welders: These welders use inert gas for light metal work (e.g., stainless steel, aluminum, etc.).

23.3 Common hazards associated with welding include the following:

23.3.1 Electrocutation

23.3.2 Burns

23.3.3 UV radiation exposure

23.3.4 Oxygen depletion

23.3.5 Sparking



23.4 In addition to the general guidelines for welding and cutting, follow these specific guidelines for safe welding operations:

23.4.1 Make sure the welding area has a non-reflective, noncombustible surface.

23.4.2 Ensure that adequate ventilation and exhaust are available.

23.4.3 Be aware of electrocution hazards, particularly in damp conditions. Be sure that electrical cords are properly grounded. It is advisable for cords to pull down from an overhead pulley.

24.0 Cutting Guidelines

24.1 Gas welding and cutting tools are often powered by oxygen or acetylene gas cylinders. These tanks require special safety precautions to prevent explosions and serious injuries. Follow the safety guidelines below, and refer to the Laboratory Safety chapter in this manual for more information on gas cylinders safety:



24.1.1 Ensure that acetylene/oxygen systems are equipped with flame or flashback arrestors attached to the regulators.

24.1.2 Store acetylene bottles upright and secured.

24.1.3 Keep cylinder fittings and hoses free from oil and grease.

24.1.4 Repair or replace defective hoses by splicing. Do not use tape.

24.1.5 Do not tamper or attempt to repair cylinders, valves, or regulators.

24.1.6 Do not interchange regulators or pressure gauges with other gas cylinders.

24.1.7 Carefully purge hoses and torches before connecting a cylinder.

24.1.8 Set acetylene pressure at or below 15 psig. Always use the minimum acceptable flow rate.

24.1.9 Never use a match to light a torch. Use an approved lighter.

END OF SECTION

V. ELECTRICAL SAFETY

1.0 General Electrical Safety

- 1.1 The danger of injury through electrical shock is possible whenever electrical power is present. When a person's body completes a circuit and thus connects a power source with the ground, an electrical burn or injury is imminent. Most fatal injuries result from high-voltage exposure; however, people can sustain severe injuries from low voltage power if it has a high current flow. Electrical safety is important in every work environment. The following sections cover circuit breaker loads, electrical grounding, electrical safety guidelines, and electrical emergency response.



2.0 Definitions

- 2.1 The following definitions help clarify general electrical safety:
- 2.1.1 Amps: The standard unit for measuring electrical current.
 - 2.1.2 Watt: A unit of electrical power, equal to the power developed in a circuit by a current of amp flowing through a potential difference of one volt.
 - 2.1.3 Voltage: Electromotive force expressed in volts.
 - 2.1.4 Circuit Breaker: A device that automatically interrupts the flow of an electrical current.
 - 2.1.5 Breaker Box: An insulated box on which interconnected circuits are mounted.
 - 2.1.6 Electrical Panel: An insulated panel on which electrical wires are mounted.
 - 2.1.7 Current Flow: The rate of flow of an electrical charge, generally expressed in amps.
 - 2.1.8 Electrical Load: The amount of power delivered by a generator or carried by a circuit. A device to which the power is delivered.
 - 2.1.9 Ground-Fault Circuit Interrupter (GFCI): A GFCI detects grounding problems and shuts electricity off to prevent a possible accident.
 - 2.1.10 High Voltage: The term high voltage applies to electrical equipment that operates at more than 600 Volts (for terminal to terminal operation) or more than 300 Volts (for terminal to ground operation). Low voltage, high current AC or DC power supplies are also considered to be high voltage.
 - 2.1.11 Hazardous Energy Sources: This term applies to stored or residual energy such as that in capacitors, springs, elevated machine members, rotating flywheels, hydraulic systems, and air, gas, steam, or water pressure.
 - 2.1.12 Lockout: The placement of a lock on an energy-isolating device. This act prevents workers from operating a piece of equipment until the lock is removed.

- 2.1.13 Tagout: The placement of a tag on an energy-isolating device. A tagout device is a prominent warning device of a lockout.
- 2.1.14 Energy-Isolating Device: A mechanical device that prevents the transmission or release of energy. Examples include the following:
 - 2.1.14.1 Manually operated circuit breakers
 - 2.1.14.2 Disconnect switches
 - 2.1.14.3 Line or block valves
- 2.1.15 Pushbuttons, selector switches, and other control circuit devices do not isolate energy. Energy-isolating devices should be lockable by means of a hasp or other type of attachment. It should not be necessary to dismantle or reassemble a device to lock it.
- 2.1.16 Authorized Employee: A person who lock out or tag out equipment for service or maintenance. Authorized employees have been formally trained in proper lockout/tagout procedures.

3.0 Circuit Breaker Loads

- 3.1 Most office and laboratory locations have 20 amp circuit breakers that serve two or more outlets. These breakers can handle most office equipment; however, the widespread use of personal computers and associated hardware can create an electrical overload. To determine your current electrical load, follow these steps:



- 3.1.1 Check office/laboratory equipment for a manufacturer's rating label that indicates total watts or amps. Take special care to check appliances that use electricity to generate heat.
- 3.1.2 Convert the watts rating to amps:
 - 3.1.2.1 $\text{Amps} = \text{Watts} \div \text{Voltage (typically 120 Volts)}$
- 3.1.3 Total the amps for each circuit.
- 3.1.4 If the total equals more than 15 amps per 20 amp circuit, you may be overloading the circuit. Move enough equipment to a different circuit to reduce the circuit load; otherwise, have the Physical Plant inspect the circuit wiring.

4.0 Electrical Grounding

- 4.1 Proper electrical grounding can help prevent electrical injury. Most electrical equipment is grounded with either a three-prong plug or a two-prong plug and insulation.



Because a grounding system may be defective without your knowledge, use a GFCI to ensure electrical safety. GFCIs are required in moist or potentially damp environments, near water sources, etc. Contact Physical Plant for assistance if a GFCI may be needed.

5.0 Electrical Panels

- 5.1 Electrical panels or breaker boxes require special safety considerations, including the following:
 - 5.1.1 Know where your panel box is located.
 - 5.1.2 Do not tape circuit switches to keep a breaker from tripping.
 - 5.1.3 Ensure that breaker circuits are accurately labeled within panel boxes.
 - 5.1.4 Ensure that panel box doors are securely attached.
 - 5.1.5 Do not block panel boxes. There should be at least 30 inches of clear space in front of a panel box.
 - 5.1.6 Make sure there are no missing pop-outs on the electrical panel.
- 5.2 Report tripped breakers and refer any electrical questions to the Facilities Services.

6.0 Electrical Safety Guidelines

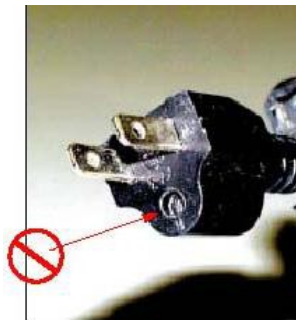

- 6.1 Follow these guidelines for general electrical safety:
 - 6.1.1 Be familiar with the electrical hazards associated with your workplace.
 - 6.1.2 Unplug electrical equipment before repairing or servicing it.
 - 6.1.3 If a prong breaks off inside an outlet, do not attempt to remove it yourself. Call Facilities Services for assistance.
 - 6.1.4 Ensure that outlets are firmly mounted. Report loose outlets to Facilities Services
 - 6.1.5 Report all electrical problems, including tripped breakers, broken switches, and flickering lights, to the Facilities Services.
 - 6.1.6 All appliances used in TAMIU buildings must be UL or FM (Factory Mutual) labeled.
 - 6.1.7 Do not use an appliance that sparks, smokes, or becomes excessively hot, unless the appliance is specifically designed to exhibit these characteristics.
 - 6.1.8 Portable electrical heaters are discouraged for reasons of energy conservation. However, if approved by a supervisor, they must be placed to avoid causing a trip hazard and must be kept away from combustible



material. Never leave a heater unattended. Unplug the heater at the end of the day or when not in use.

- 6.1.9 Keep electrical equipment away from water, unless the appliance is specifically designed for use around water, such as a wet-dry shop vacuum.
- 6.1.10 Use GFCIs whenever possible.
- 6.1.11 Be aware of overhead power lines when working with tall equipment (e.g., grain augers, cranes, sailboats, etc.).
- 6.1.12 Follow lockout/tagout procedures, as appropriate. Refer to Section 8.0 below.

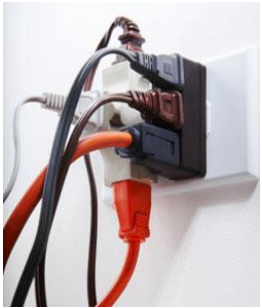
6.2 Follow these guidelines for electrical plug and cord safety:

- 6.2.1 Do not remove the prongs of an electrical plug. If plug prongs are missing, loose, or bent, replace the entire plug or the cord and plug.
- 6.2.2 Do not use an adapter or extension cord to defeat a standard grounding device. (i.e., only place three-prong plugs in three-prong outlets; do not alter them to fit in a two-prong outlet.)
- 6.2.3 Use extension cords only when necessary and only on a temporary basis. Do not use extension cords in place of permanent wiring. Request new outlets if your work requires equipment in an area without an outlet. 
- 6.2.4 Use extension cords that are the correct size or rating for the equipment in use. The diameter of the extension cord should be the same or greater than the cord of the equipment in use.
- 6.2.5 Do not run electrical cords above ceiling tiles or through walls.
- 6.2.6 Keep electrical cords away from areas where they may be pinched and areas where they may pose a tripping or fire hazard (e.g., doorways, walkways, under carpet, etc.) 
- 6.2.7 Avoid plugging more than one appliance in each outlet. If multiple appliances are necessary, use an approved power strip with surge protector and circuit breaker. Do not overload the circuit breaker.
- 6.2.8 Discard damaged cords, cords that become hot, or cords with exposed wiring.
- 6.2.9 Never unplug an appliance by pulling on the cord; pull on the plug. 
- 6.2.10 Always unplug and secure an extension cord when not in use.

7.0 Electrical Emergency Response

7.1 The following instructions provide guidelines for handling three types of electrical emergencies:

7.1.1 Electric Shock: When someone suffers serious electrical shock, he or she may be knocked unconscious. If the victim is still in contact with the electrical current, immediately turn off the electrical power source. If you cannot disconnect the power source, try to separate the victim from the power source with a nonconductive object, such as a wood-handled broom.



7.1.2 **IMPORTANT:** *Do not touch a victim that is still in contact with a power source; you could electrocute yourself.*

7.1.3 Have someone call for emergency medical assistance immediately. Administer first-aid, as appropriate.

7.1.4 Electrical Fire: If an electrical fire occurs, try to disconnect the electrical power source, if possible. If the fire is small, you are not in immediate danger, and you have been trained in fighting fires, use any type of fire extinguisher **except water** to extinguish the fire.



7.1.5 **IMPORTANT:** *Do not use water on an electrical fire. Instead use a fire extinguisher approved for electrical fire use.*

7.1.6 Power Lines: Stay away from live power lines and downed power lines. Be particularly careful if a live power line is touching a body of water. The water could conduct electricity. If a power line falls on your car while you are inside, remain in the vehicle until help arrives.

8.0 Lockout/Tag-out Procedures

8.1 Texas A&M International Environmental Health & Safety Lockout/Tag-out Program

8.1.1 Failure to Follow Proper Procedures When Using the Lockout/Tag-out System Will Result In Disciplinary Action

8.2 Preplanning for Lockout (Preparation for Shutdown)

An initial survey shall be made to determine which switches, valves, or other energy isolating devices apply to the equipment being locked out. More than one energy source (electrical, mechanical, hydraulic, pneumatic, chemical, thermal, or

others) may be involved. Any questionable identification of sources shall be cleared by the employees with their supervisors. Before lockout commences, job authorization should be obtained from the supervisor.

8.2.1 Only supervisors or authorized individuals shall prescribe the appropriate duties and responsibilities relating to the actual details of affecting the lockout/tag-out. Energy isolating devices shall be operated only by authorized individuals or under the direct supervision of authorized individuals. Where high voltages greater than 480V are involved the supervisor electrician shall be responsible for turning off the main power controls.

8.2.2 All energy isolating devices shall be adequately labeled or marked to indicate their function. The identification shall include the following:

8.2.2.1 Equipment supplied

8.2.2.2 Energy type and magnitude



8.2.3 Where system complexity requires, a written sequence in checklist form should be prepared for equipment access, lockout/tag-out, clearance, release, and start-up.

8.3 Lockout/Tag-out Procedures preparation

8.3.1 Notify all affected employees/ building occupants that a lockout is required and the reason therefore.

8.3.2 Contact necessary departments and personnel

8.3.3 Only authorized personnel are to secure lockout/tag-out device. Authorized personnel include managers, shop supervisors, area maintenance supervisors.

8.3.4 Machine or Equipment Shutdown

8.3.4.1 If the equipment is operating, shut it down by the normal stopping procedure (depress stop button, open toggle switch, etc.). Disconnect switches should never be pulled while under load, because of the possibility of arcing or even explosion. Personnel knowledgeable of equipment operation should be involved with shut down or re-start procedures.

8.3.5 Machine or Equipment Isolation

8.3.5.1 Operate the switch, valve, or other energy-isolating device so that the energy source(s) (electrical, mechanical, hydraulic, etc.) is (are) disconnected or isolated from the equipment. Stored energy, such as that in capacitors, springs, elevated machine members, rotating flywheels, hydraulic systems, and air, gas, steam, or water pressure, etc., must also be dissipated, disconnected, or restrained by methods such as grounding, repositioning, blocking, bleeding-down, etc. Pulling a fuse is not a substitute for locking out. A pulled fuse is no guarantee the circuit is dead, and even if it were dead, there's nothing to stop someone from inadvertently replacing the fuse.

8.3.5.2 CAUTION: Intermittently operating equipment such as pumps, blowers, fans, and compressors may seem harmless when dormant. Don't assume that because equipment isn't functioning, it will stay that way.

8.3.6 Application of Lockout/Tag-out

8.3.6.1 Lockout and tag the energy isolating device with an assigned individual lock, even though someone may have locked the control before you. You will not be protected unless you put your own padlock on it. For some equipment it may be necessary to construct attachments to which locks can be applied. An example is a common hasp to cover an operating button. Tags shall be attached to the energy isolating device(s) and to the normal operating control and shall be attached in such a manner as to preclude operation.

8.3.7 Verification of Isolation

8.3.7.1 After ensuring that no personnel can be exposed and as a check on having disconnected the energy sources, operate the push button or other normal operating controls to make certain the equipment will not operate.

8.3.7.2 If there is a possibility of re-accumulation of stored energy to a hazardous level, verification of isolation shall be continued until the maintenance or repair is completed, or until the possibility of such accumulation no longer exists.

8.3.7.3 CAUTION: Return operating controls to neutral position after the test. A check of system activation (e.g. use of voltage indicator for electrical circuits) should be used to assure isolation.

8.3.8 The equipment is now locked out.

8.4 Release from Lockout/Tag-out

- 8.4.1 Before lockout or tag-out devices are removed and energy is restored to the machine or equipment, inspect the work area to ensure that nonessential items have been removed and to ensure that machine or equipment components are operationally intact.
 - 8.4.2 Check work area to ensure that all employees are in the clear. Notify affected employees that lockout/tag-out devices have been removed.
 - 8.4.3 The employee who applied the device shall remove each lockout/tag-out device from each energy-isolating device. The energy isolating devices may be opened or closed, to restore energy to equipment.
 - 8.4.4 Contact authorized personnel when energy is restored and return lockout/tag-out device. (Proper Documentation Required)
- 8.5 Lockout/Tag-out Interruption (Testing of Energized Equipment)
- 8.5.1 In situations where the energy isolating device(s) is lockout/tagged and there is a need for testing or positioning of the equipment/process, the following sequence shall apply:
 - 8.5.1.1 Make sure to Clear equipment and/or process of tools and materials.
 - 8.5.1.2 Make sure all personnel are clear of danger.
 - 8.5.1.3 Remove the control of locks/tags according to established procedure.
 - 8.5.1.4 Proceed with test, etc.
 - 8.5.1.5 De-energize all systems and re-lockout /re-tag-out the controls to continue the work.
- 8.6 Procedure Involving More Than One Person
- 8.6.1 In the preceding steps, if more than one individual is required to lock out equipment, each shall place a personal lock and tag on the group lockout device when he/she begins work, and shall remove those devices when he/she stops working on the machine or equipment. The supervisor, with the knowledge of the crew, may lock out equipment for the whole crew. In such cases, it shall be the responsibility of the supervisor to carry out all steps of the lockout procedure and inform the crew when it is safe to work on the equipment. Additionally, the supervisor shall not remove a crew lock until it has been verified that all individuals are clear.
 - 8.6.2 Scheduled Leave
 - 8.6.2.1 If the owner of the device (owner being the person who installed the lockout/tag-out device) is going on scheduled leave and

someone else may need to work on the locked out unit, they must remove their lock and have it replaced by a new owner who is on regular duty.

8.7 Conditions for lockout/tag-out removal by Authorized Personnel

- 8.7.1 Only the owner of the device shall remove lockout/tag-out devices.
- 8.7.2 Exceptions to the conditions of removal:
 - 8.7.2.1 Owner incapacitated by illness or injury then his/her supervisor shall remove the lockout/tag-out device.
 - 8.7.2.2 Owner is no longer employed by Texas A&M University, and then his/her supervisor shall remove the lockout/tag-out device.
 - 8.7.2.3 If Authorized Personnel determines that circumstances warrant removal of a lockout/tag-out device, every effort must be made to contact the owner of the device. After the above conditions have been met the Authorized Personnel may remove device.

9.0 High Voltage Procedures

9.1 In addition to the guidelines associated with general electrical safety and lockout/tagout procedures, there are more stringent safety requirements for high voltage procedures.



- 9.2 The following list provides high-voltage safety tips. For more information, please refer to [Electric Power Generation, Transmission, and Distribution. - 1910.269](#) or NFPA 70: National Electrical Code®
- 9.2.1 Ensure that only authorized employees work around high voltage equipment.
 - 9.2.2 Label entrances with a High Voltage Sign.
 - 9.2.3 Ensure that terminal voltage ratings can withstand surges caused by electrical faults or switching transients.
 - 9.2.4 Be careful around output circuits even when the input power is off. Parallel power sources and energy storage devices can still be dangerous.
 - 9.2.5 Be careful when working with power supplies that serve more than one area.
 - 9.2.6 Before working in a high voltage area, inspect the power supply and check all protective devices.
 - 9.2.7 Do not work alone near high voltage.
 - 9.2.8 Label equipment to identify power sources. Label input power sources to identify connected power supply loads.
 - 9.2.9 Attach emergency shutdown instructions and phone numbers to equipment that is remotely controlled or unattended while energized.

9.3 Before entering a power supply or associated equipment enclosure to work on hazardous energy sources, complete the following:

9.3.1 De-energize the equipment.

9.3.2 Open and lockout the main input power circuit breaker.

9.3.3 Check for auxiliary power circuits that could still be energized.

9.3.4 Inspect automatic shorting devices for proper operation.

9.3.5 Short the power supply with grounding hooks.



10.0 Minimum Clear Working Space

10.1 As per State Fire Marshal recommendations, all electrical panels must have a minimum clearance of 3 feet.

END OF SECTION

VI. CONSTRUCTION SAFETY

1.0 General Construction Guidelines

1.1 Construction work can be particularly hazardous. Personal protective equipment, fire safety, electrical safety, confined space entry, emergency preparedness, biological safety, chemical safety, hazardous waste disposal, vehicle safety and other precautions are essential for safe construction work. Refer to other chapters in this manual for more information. Follow these guidelines when visiting or working at construction sites:

- 1.1.1 Do not walk, stand, or work under suspended loads. If you raise a load, be sure to crib, block, or otherwise secure the load as soon as possible.
- 1.1.2 Avoid placing unusual strain on equipment or materials.

1.2 Be prepared for unexpected hazards. **BE ALERT!**

2.0 Barriers and Guards

2.1 University employees must use barriers and guards as necessary to protect employees, students, contractors, and visitors from physical hazards. If you suspect a hazard is not sufficiently protected, notify the attending workers or Environmental Health & Safety immediately.



NOTE: Barriers, guards, and warning signs are required to ensure safety against existing hazards.

3.0 Types of Barriers and Guards

3.1 Standard types of barriers and guards include the following:

- 3.1.1 Guardrails and handholds
- 3.1.2 Saw horses
- 3.1.3 Tape
- 3.1.4 Toeboards
- 3.1.5 Cones
- 3.1.6 Other physical barriers and solid separators (dust barriers, hazard barriers, temporary walkways, etc.)



NOTE: Signs that state **DANGER**, **WARNING**, or **CAUTION** are also important when barriers or guards are necessary. Remember to make signs legible, visible, and brief.

4.0 Areas that Need Barriers or Guards

4.1 Any area that poses a physical threat to workers and/or pedestrians requires barriers or guards. Areas that typically require permanent or temporary protection include the following:

- 4.1.1 Stairways
- 4.1.2 Hatches
- 4.1.3 Chutes
- 4.1.4 Open Manholes
- 4.1.5 Elevated platforms
- 4.1.6 Areas with moving machinery
- 4.1.7 Excavation sites
- 4.1.8 Construction sites
- 4.1.9 Temporary wall or floor openings

5.0 Using Barriers and Guards

5.1 The following list provides guidelines for using barriers and guards:

- 5.1.1 When necessary, reroute pedestrian and vehicular traffic to completely avoid a construction site.
- 5.1.2 Guard any permanent ground opening into which a person could fall with a guardrail, load-bearing cover, or other physical barrier.
- 5.1.3 Ensure that temporary floor openings, such as pits and open manholes, are guarded by secure, removable guardrails. If guardrails are not available, have someone guard the opening.
- 5.1.4 Ensure that all stairways, ladderways, hatchways, or chute floor openings have handrails or hinged covers.
- 5.1.5 Ensure that enclosed stairways with four or more steps have at least one railing, and that open stairways with four or more steps have two railings.
- 5.1.6 Ensure that all platforms and walkways that are elevated or located next to moving machinery are equipped with handrails, guardrails, and toeboards.
- 5.1.7 Barricade any wall openings through which a person or tools could fall. Use gates, doors, guardrails, or other physical barriers to block the opening.
- 5.1.8 Mark and guard any excavation that is deeper than 12 inches.
- 5.1.9 Mark and/or guard potholes and sidewalk damage as appropriate.
- 5.1.10 Protect smoke detectors with some type of cover when construction work, such as dust or fume producing activities, may affect smoke detectors. Remove protectors immediately at the end of the activity or at the end of the each day.



6.0 Heavy Equipment Safety

6.1 When using heavy equipment, there are five basic guidelines that employees must always follow to ensure safety:

6.1.1 Know how to properly operate the equipment you are using. Training on proper operation shall be documented.

6.1.2 Do not use heavy machinery when you are drowsy, intoxicated, or taking prescription medication that may affect your performance.

6.1.3 Use only equipment that is appropriate for the work to be done.

6.1.4 Inspect your equipment to ensure that it is in good working condition before beginning a job. In addition, ensure that regular inspections and maintenance are conducted as appropriate.

6.1.5 Do not stress or overload your equipment.



6.2 Accidents do not just happen, they are caused. Therefore, employees should also follow these guidelines:

6.2.1 Ensure the following before leaving equipment unattended:

6.2.1.1 All buckets, blades, etc. are on the ground.

6.2.1.2 Transmission is in neutral.

6.2.1.3 Engine is off.

6.2.1.4 Equipment is secure against movement.

6.2.1.5 Never get on or off moving equipment.

6.2.1.6 Do not attempt to lubricate or adjust a running engine.

6.2.1.7 Turn the engine off before refueling.

6.2.1.8 Keep all shields and safety guards in place.

6.2.1.9 Avoid underground utilities and overhead power lines.

6.3 The following sections provide basic guidelines for working with forklifts, front-end loaders, and backhoes. Refer to the product documentation that accompanied your equipment for more information and specific instructions.

7.0 Forklifts

7.1 Only authorized employees may operate forklifts. The following list provides general safety guidelines:



7.1.1 Do not allow riders. Do not raise people on a forklift.

7.1.2 Always wear your safety belt.

7.1.3 Never leave keys in an unattended forklift.

7.1.4 Do not speed.

- 7.1.5 Drive up and back down ramps.
 - 7.1.6 Do not walk, stand, or work under the elevated portion of a forklift (even if it is not loaded).
 - 7.1.7 Ensure that the forklift has an overhead barrier to protect the operator from falling objects.
- 7.2 In addition, follow these guidelines for safe forklift operation:
- 7.2.1 Always work within the capacity limits of your forklift. Consult with the manufacturer before modifying the operation or capacity limits of a forklift.
 - 7.2.2 Do not operate a forklift in areas with hazardous concentrations of acetylene, butadiene, hydrogen, ethylene, or diethyl ether, or other explosive environment.
 - 7.2.3 Never lift a load while moving. Wait until you are completely stopped before raising the mast.
 - 7.2.4 Be sure the top load sits squarely on the stack. An uneven load could topple.
 - 7.2.5 Travel with loads slightly tilted back to provide stability.
 - 7.2.6 Travel with loads at the proper height. A stable clearance height is usually 4 to 6 inches at the tips and 2 inches at the heels of fork blades.
 - 7.2.7 Lift stacked loads in the same manner as loads on the floor.
 - 7.2.8 When preparing to leave the forklift unattended, lower the mast, neutralize the controls, shut the power off, and set the brakes. The forklift is "unattended" when the operator is more than 25 feet away or the forklift is out of view.
 - 7.2.9 When ascending or descending a grade in excess of 10 percent, drive the forklift with the load upgrade.
 - 7.2.10 If you cannot see over a load, drive in reverse. Do not try to look around a load and drive forward.
- 7.3 Contact the Environmental Health and Safety Occupational Safety for Forklift training and certification information.

8.0 Backhoes

- 8.1 Only authorized employees may operate backhoes and front-end loaders. The following list offers general safety guidelines for both types of machinery:
- 8.1.1 Always operate at a safe speed.
 - 8.1.2 Travel with the bucket low to the ground.
 - 8.1.3 Always lower the bucket before servicing the equipment or leaving the loader unattended.
 - 8.1.4 Use a rigid-type coupler when towing loads.
 - 8.1.5 Always check with the utility company before digging.
 - 8.1.6 Be extremely careful when operating near



banks and slopes.

- 8.1.7 When cutting a bank, be careful not to cause a cave-in. Do not drive on an overhang.

9.0 Hoists

9.1 Only authorized employees may use hoists to move heavy objects and equipment. When using hoists, remember to follow the five safety guidelines for working with heavy equipment found above in section 6.0. In addition, follow the guidelines in the following sections.



10.0 Hoisting Guidelines

10.1 The following are general guidelines for working with hoists:

- 10.1.1 Never walk, stand, or work beneath a hoist.
- 10.1.2 Isolate hoisting area with barriers, guards, and signs, as appropriate.
- 10.1.3 Never exceed the capacity limits of your hoist.
- 10.1.4 Wear gloves and other personal protective equipment, as appropriate, when working with hoists and cables.
- 10.1.5 Ensure that hoists are inspected regularly before each use.
- 10.1.6 Ensure that hoists are inspected annually by a certified inspector through EHS.
- 10.1.7 Always hold tension on the cable when reeling it in or out.
- 10.1.8 When the work is complete, always rig the hoist down and secure it.
- 10.1.9 When the load block or hook is at floor level or its lowest point of travel, ensure that at least two turns of rope remain on the drum.
- 10.1.10 Be prepared to stop operations immediately if signaled by the safety watch or another person.

11.0 Picking Up Loads with Hoists

- 11.1 Ensure that the hoist is directly above a load before picking it up. This keeps the hoist from becoming stressed. Picking up loads at odd angles may result in injury to people or damage to the hoist.
- 11.2 Do not pick up loads by running the cable through, over, or around obstructions. These obstructions can foul the cable or catch on the load and cause an accident.

12.0 Avoiding Electrical Hazards with Hoists

- 12.1 Do not hoist loads when any portion of the hoisting equipment or suspended load can come within 6 feet of high-voltage electrical lines or equipment.

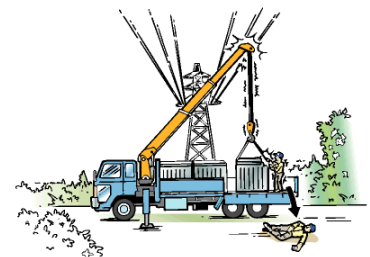

- 12.2 If you need to hoist near high-voltage electrical lines or equipment, obtain clearance from your supervisor first.

13.0 Inspecting Hoists

- 13.1 Hoists should be inspected daily. If there is any question about the working condition of a hoist, do not use it.
- 13.2 Hoist inspectors should note the following:
- 13.2.1 The hooks on all blocks, including snatch blocks, must have properly working safety latches.
 - 13.2.2 All hooks on hoisting equipment should be free of cracks and damage.
 - 13.2.3 The maximum load capacity for the hoist must be noted on the equipment.
 - 13.2.4 Cables and wiring should be intact and free of damage.

14.0 Mobile Crane Safety Procedures

- 14.1 In the initial survey of crane operations, look for crane stability, physical Obstructions to movement or operation, and proximity of electrical power lines, as well as the following:
- 14.1.1 *Leveling*_Has the crane operator set the crane up level and in a position for safe rotation and operation?
 - 14.1.2 *Outriggers*_Are the outriggers, where applicable, extended and being used in accordance with manufacturer's recommendations?
 - 14.1.3 *Stability*_The relationship of the load weight, angle of boom, and its radius (the distance from the cranes center of rotation to the center of load) to the center of gravity of the load. Also, the condition of crane loading where the load moment acting to overturn the crane is less than the moment of the crane available to resist overturning.
 - 14.1.4 *Structural Integrity* The crane's main frame, crawler, track and outrigger supports, boom sections, and attachments are all considered part of structural components of lifting. In addition, all wire ropes, including stationary supports, help determine lifting capacity and are part of the structural elements of crane operations.
 - 14.1.5 *Access to Job Site* The site must be secured by barricades (caution tape or fencing) to prevent unauthorized entry to the area by: Faculty, Staff, Students, Visitors, and Construction Personal. The barricades must encompass the length the boom is extended and the area the boom will swing.

- 14.2 Crane operators and personnel working with cranes need to be knowledgeable of basic crane capacities, limitations, and specific job site restrictions, such as access restrictions to job site, location of overhead electric power lines, and high wind conditions. Personnel working around crane operations also need to be aware of hoisting activities or any job restrictions imposed by crane operations, and ensure job site coordination of cranes. Crane operators should be aware of these issues and, prior to starting crane activity, take time to observe the overall crane operations with respect to load capacity, site coordination, and any job site restrictions in effect.
- 14.3 Accidents can be avoided by careful job planning. The person in charge must have a clear understanding of the work to be performed and consider all potential dangers at the job site. A safety plan must be developed for the job and must be explained to all personnel involved in the lift.

15.0 Fall Protection Program

- 15.1 Fall Protection Requirements
This Program prescribes the duty to provide fall protection, sets the criteria and practices for fall protection systems, and required training.
- 15.2 In the construction industry in the U.S., falls are the leading cause of worker fatalities. Each year, on average, between 150 and 200 workers are killed and more than 100,000 are injured as a result of falls at construction sites alone.
- 15.3 Standards for fall protection deal with both the human and equipment-related issues in protecting workers from fall hazards. Employers and employees are required to do the following:
 - 15.3.1 Where protection is required, select fall protection systems appropriate for given situations.
 - 15.3.2 Use proper construction and installation of safety systems.
 - 15.3.3 Supervise employees properly.
 - 15.3.4 Use safe work procedures.
 - 15.3.5 Train workers in the proper selection, use, and maintenance of fall protection systems.
- 15.4 This Program covers everyone except those inspecting, investigating, or assessing workplace conditions prior to the actual start of work or after all work has been completed.
- 15.5 This Program identifies areas or activities where fall protection is needed. These include, but are not limited to, ramps, runways, and other walkways, excavations, hoist areas, holes, formwork and reinforcing steel, leading edge work, unprotected side and edges, overhand bricklaying and related work, roofing work, precast concrete erection, wall openings, residential construction, and other

walking/working surfaces. The rule sets a uniform threshold height of 6 feet, thereby providing consistent protection. This means that employers must protect employees from fall hazards and falling objects when ever an affected employee is 6 feet or more above a lower level. Protection also must be provided for workers who are exposed to the hazard of falling into dangerous equipment.

15.6 General Fall Protection

15.6.1 Employers must assess the workplace to determine if the walking or working surfaces on which employees are to work have the strength and structural integrity to safely support the workers. Once the employer has determined that the surface is safe for the employees to work on, the employer must provide the proper fall protection for the fall hazard that is present. The employer must provide fall protection for employees, after identifying and evaluating fall hazards and providing specific training.

15.7 Controlled Access Zones

15.7.1 A controlled access zone is a work area designated and clearly marked in which certain types of work (such as overhand bricklaying) may take place without the use of conventional fall protection systems-guardrail, personal arrest or safety-net to protect the employees working in the zone. Controlled access zones are used to keep out workers other than those authorized to enter work areas from which guardrails have been removed. Where there are no guardrails, masons are the only workers allowed in controlled access zones. Controlled access zones, when created for leading edge work is taking place, must be defined by a control line or by any other means that restricts access. Control lines shall consist of ropes, wires, tapes or equivalent materials, and supporting stanchions, and must be:

- 15.7.1.1 Flagged or otherwise clearly marked at not more than 6-foot intervals with high-visibility material.
- 15.7.1.2 Rigged and supported in such a way that the lowest point is not less than 39 inches from the walking/working surface and the highest point is not more than 45 inches (50 inches for overhand bricklaying) from the walking/working surface.
- 15.7.1.3 Strong enough to sustain stress of not less than 200 pounds. Control lines shall extend along the entire length of the unprotected or leading edge and shall be approximately parallel to the unprotected or leading edge.
- 15.7.1.4 Control lines also must be connected on each side to a guardrail system or wall

15.8 Guardrail Systems

15.8.1 If the employer chooses to use guardrail systems to protect workers from falls, the systems must meet the following criteria:

- 15.8.1.1 Toprails and midrails of guardrail systems must be at least one-quarter inch nominal diameter; it must be flagged at not more than 6 feet intervals with high-visibility material, and must be inspected as frequently as necessary to ensure strength and stability. The top edge height of toprails or guardrails must be 42 inches plus or minus 3 inches above the walking/working level.
- 15.8.1.2 When midrails are used, they must be installed at a height midway between the top edge of the guardrail system and the walking/working level and there shall be no openings in the guardrail system more than 19 inches.
- 15.8.1.3 The guardrail system must be capable of withstanding a force of at least 200 pounds applied within 2 inches of the top edge in any outward or downward direction and must not deflect to a height less than 39 inches above the walking/working level.
- 15.8.1.4 Midrails, screens, mesh, intermediate vertical members, solid panels, and equivalent structural members shall be capable of withstanding a force of at least 150 pounds applied in any downward or outward direction at any point along the midrail or other member.
- 15.8.1.5 When guardrail systems are used at hoisting areas, a chain, gate or removable guardrail section must be placed across the access opening between guardrail sections when hoisting operations are not taking place.
- 15.8.1.6 At holes, guardrail systems must be set up on all unprotected sides or edges. When holes are used for the passage of materials, the hole shall not have more than two sides with removable guardrail sections.
- 15.8.1.7 If guardrail systems are around holes that are used as access points (such as ladderways), gates must be used or the point of access must be offset to prevent accidental walking into the hole.
- 15.8.1.8 If guardrails are used at unprotected sides or edges of ramps and runways, they must be erected on each unprotected side or edge.
- 15.8.1.9 Around holes (including skylights) that are more than 6 feet above lower levels.
- 15.8.1.10 Excavation of 6 feet or more deep shall be protected from falling and where walkways are provided to permit foot traffic to cross over excavations, guardrails are

required on the walkway if the fall would be 6 feet or more to the lower level.

15.9 Personal Fall Protection Systems

15.9.1 This includes any of the following: an anchorage, connectors, and a full body harness and may include a deceleration device, lifeline, or suitable combinations.

15.9.2 If a personal fall arrest system is used for fall protection, it must do the following:

15.9.2.1 Limit maximum arresting force on an employee to 1,800 pounds when used with a body harness;

15.9.2.2 Be rigged so that an employee can neither free fall more than 6 feet nor contact any lower levels;

15.9.2.3 Bring an employee to a complete stop and limit maximum deceleration distance an employee travels to 3.5 feet.

15.9.2.4 Have sufficient strength to withstand twice the potential impact energy of an employee free falling a distance of 6 feet or the free fall distance permitted by the system, whichever is less.

15.9.3 Personal fall protection systems must be inspected prior to each use for wear damage, and other deterioration. Defective components must be removed from service.

15.9.4 Snaphooks shall be sided to be compatible with the member to whom they will be connected, or shall be a locking configuration.

15.9.5 Horizontal lifelines shall be designed, installed, and used under the supervision of a qualified person, as part of a complete personal fall arrest system that maintains a safety factor of at least two. Lifelines shall be protected against being cut or abraded.

15.9.6 Full body harnesses are the only acceptable harness and must be used at all times on all personnel lifting equipment, including scissor lifts (NO BELT HARNESSSES ALLOWED).

15.10 Safety Monitoring Systems

15.10.1 When no other alternative fall protection has been implemented, the employer shall implement a safety monitoring system. Employers must appoint a competent person to monitor the safety of workers and the employer shall ensure that the safety monitor:

- 15.10.1.1 Is competent in the recognition of fall hazards.
- 15.10.1.2 Is capable of warning workers of fall hazard dangers and in detecting unsafe work practices.
- 15.10.1.3 Is operating on the same walking/working surfaces of the workers and can see them.
- 15.10.1.4 Is close enough to work operations to communicate orally with workers and has no other duties to distract from the monitoring function.

15.10.2 Mechanical equipment shall be used or stored in areas where safety monitoring systems are being used to monitor employees engaged in roofing operations of low-sloped roofs. No worker, other than one engaged in roofing work (on low-sloped roofs) or one covered by a fall protection plan, shall be allowed in an area where an employee is being protected by a safety monitoring system. All workers in a controlled access zone shall be instructed to promptly comply with fall hazard warnings issued by safety monitors.

15.11 Toeboards

15.11.1 When toeboards are used as protection from falling objects, they must be erected along the edges of the overhead walking or working surface for a distance sufficient to protect persons working below. Toeboards shall be capable of withstanding a force of a least 50 pounds applied in any downward outward direction at any point along the toeboard. Toeboards shall be a minimum of 3.5 inches tall from their top edge to the level of the walking/working surface, have no more than 0.25 inches clearance above the walking/working surface, and be solid or have openings no larger than 1 inch in size. Where tools, equipment, or materials are piled higher than the top edge of a toeboard, paneling or screening must be erected the walking/working surface or toeboard to the top of a guardrail system's top rail or midrail, for a distance sufficient to protect employees below.

15.12 Hoist Areas

15.12.1 Each employee in a hoist area shall be protected from falling 6 feet or more by guardrail systems or personal fall arrest systems. If guardrail systems (or chain gate or guardrail) or portions thereof must be removed to facilitate hoisting operations, as during the landing of materials, and a worker must lean through the access opening or out over the edge of the access opening to receive or guide equipment and materials, that employee must be protected by a personal fall arrest system.

15.13 Ramps, Runways, and Other Walkways

15.13.1 Each employee using ramps, runways, and other walkways shall be protected by guardrails systems against falling 6 feet or more.

15.14 Steep Roofs

15.14.1 Each employee on a steep roof with unprotected sides and edges 6 feet or more above lower levels shall be protected by either guardrail systems with toeboards, a safety net system, or a personal fall arrest system.

15.15 Wall Openings

15.15.1 Each employee working on, at, above, or near wall openings (including those with chutes attached) where the outside bottom edge of the wall opening is 6 feet or more above lower levels and the inside bottom edge of the wall opening is less than 39 inches above the walking/working surface must be protected from falling by the use of either a guardrail system, a safety net system, or a personal fall arrest system.

15.16 Ladders

15.16.1 Ladders can make many tasks easier, but they are also a continual safety hazard. Even the best ladder is not safe unless you are trained and proficient in using ladders. Each year, many people suffer serious injuries from accidents involving ladders. Before you use a ladder, take a moment to think about doing it safely.

15.16.2 A secure, well made ladder is necessary for safe ladder use. Ladders come in different styles, including step, straight, and extension. They also vary in construction and may consist of wood, aluminum, or fiberglass. Choose the correct type and size ladder for the job. All ladders sold within the U.S. are rated as follows:

Type IA: Heavy-duty industrial ladder rated to hold up to 300 pounds.

Type II: Medium-duty commercial ladder rated to hold up to 225 pounds.

Type III: Light-duty household ladder rated to hold up to 200 pounds

15.16.3 Follow these guidelines for safe ladder usage:

- 15.16.3.1 Always inspect a ladder before you climb it. Make sure the steps are sturdy and the locking mechanisms are in good working order.
- 15.16.3.2 Carry ladders horizontally with the front end slightly higher than the back end.
- 15.16.3.3 To open a stepladder, make sure the spreader is locked and the pail shelf is in position. To open an extension ladder, brace the bottom end and push the rungs or rails out.
- 15.16.3.4 Place ladders on a solid, level surface to ensure safety.
- 15.16.3.5 Watch for overhead obstructions and power-lines.
- 15.16.3.6 To prevent ladders from sinking into soft ground, use a large board under the feet of the ladder.
- 15.16.3.7 Position a straight or extension ladder so that the use of the ladder is one foot away from the vertical support for every four feet of working ladder height (e.g., if you are working with eight feet of ladder, place the base of the ladder two feet from the wall).
- 15.16.3.8 Do not place the top of a ladder against a window or an uneven surface.
- 15.16.3.9 Tie the top of a straight or extension ladder to supports.
- 15.16.3.10 An extension ladder used for access to a roof must extend at least 3 feet beyond the support point.
- 15.16.3.11 Use a wooden or plastic ladder if you must work near electrical sources.
- 15.16.3.12 Do not place a ladder in front of a door unless you lock and barricade the door and post a warning sign on the opposite side of the door.
- 15.16.3.13 Use common sense when climbing or working on ladders.
- 15.16.3.14 Wear shoes with slip-resistant soles and make sure they are dry before climbing.
- 15.16.3.15 Never allow more than one person on a ladder.

- 15.16.3.16 To climb or descend a ladder, face the ladder and firmly grip the rails, not the rungs, with both hands.
- 15.16.3.17 Keep your body between the rails at all times. Do not shift your weight to one side.
- 15.16.3.18 Have somebody steady the ladder if it cannot be secured otherwise.
- 15.16.3.19 Do not stand on the top four rungs of an extension ladder or the top two rungs of a step ladder.
- 15.16.3.20 When working on a ladder, keep two feet and one hand on the ladder at all times.
- 15.16.3.21 Do not stand on the bucket shelf of a ladder.
- 15.16.3.22 When working on a ladder, carry small tools on a tool belt. Use a rope to raise and lower heavy tools.
- 15.16.3.23 Never leave a raised or open ladder unattended.
- 15.16.3.24 Store ladders away from heat and moisture. Destroy damaged or unsafe ladders.

15.17 Glossary

- 15.17.1Anchorage- A secure point of attachment for lifelines, lanyards or deceleration devices.
- 15.17.2Body harness- Straps that may be secured about the person in a manner that distributes the fall-arrest forces over at least the thighs, pelvis, waist, chest, and shoulders with a means for attaching the harness to other components of a personal fall arrest system.
- 15.17.3Connector- A device that is used to couple (connect) parts of a personal fall arrest system or positioning device system together.
- 15.17.4Controlled access zone- A work area designated and clearly marked in which certain types of work (such as overhand bricklaying) may take place without the use of conventional fall protection systems-guardrails, personal arrest or safety net- to protect the employees working in the zone.
- 15.17.5Deceleration device- Any mechanism-such as rope, grab, rip-stitch lanyard, specially-woven lanyard, tearing or deforming lanyards, automatic self-retracting lifelines/lanyards-which serves to dissipate a substantial amount of energy during a fall arrest, or otherwise limits the energy imposed on an employee during fall arrest.

- 15.17.6 Deceleration distance- The additional vertical distance a falling person travels, excluding lifeline elongation and free fall distance, before stopping, from the point at which a deceleration device begins to operate.
- 15.17.7 Guardrail system- A barrier erected to prevent employees from falling to lower levels.
- 15.17.8 Hole- A void or gap 2 inches or more in the least dimension in a floor, roof, or other walking/working surface.
- 15.17.9 Lanyard- A flexible line of rope, wire rope, or strap that generally has a connector at each end for connecting the body belt or body harness to a deceleration device, lifeline, or anchorage.
- 15.17.10 Leading Edge- The edge of a floor, roof, or formwork for a floor or other walking/working surface (such as the deck) which changes location as additional floor, roof, decking, or formwork sections are placed, formed or constructed.
- 15.17.11 Lifeline- A component consisting of a flexible line for connection to an anchorage at one end to hang vertically (vertical lifeline), or for connection to anchorages at both ends to stretch horizontally (horizontal lifeline) and that serves as a means for connecting other components of a personal fall arrest system to the anchorage.
- 15.17.12 Low-slope roof- A roof having a slope less than or equal to 4 in 12 pitch (vertical to horizontal).
- 15.17.13 Opening- A gap or void 30 inches or more high and 18 inches or more wide, in a wall or partition, through which employees can fall to a lower level.
- 15.17.14 Personal fall arrest system- A system including but not limited to an anchorage, connectors, and a body harness used to arrest an employee in a fall from a working level. As of January 1, 1998, the use of a body belt for fall arrest is prohibited.
- 15.17.15 Positioning device system- A body harness system rigged to allow an employee to be supported on an elevated vertical surface, such as a wall, and work with both hands free while leaning backwards.
- 15.17.16 Rope grab- A deceleration device that travels on a lifeline and automatically, by friction, engages the lifeline and locks to arrest a fall.
- 15.17.17 Safety-monitoring system- A safety system in which a competent person is responsible for recognizing and warning employees of fall hazards.

- 15.17.18 Self-retracting lifeline/lanyards- A deceleration device containing a drum-wound line which can be slowly extracted from, or retracted onto, the drum under minimal tension during normal employee movement and which, after onset of a fall, automatically locks the drum and arrests the fall.
- 15.17.19 Snaphook- A connector consisting of a hook-shaped member with a normally closed keeper, or similar arrangement, which may be opened to permit the hook to receive an object and, when released automatically closes to retain the object.
- 15.17.20 Steep roof-A roof having a slope greater than 4 in 12 pitch (vertical to horizontal).
- 15.17.21 Toeboard- A low protective barrier that prevents material and equipment from falling to lower levels and which protect personnel from falling.
- 15.17.22 Unprotected sides and edges-Any side or edge (except at entrances to points of access) of a walking/working surface (e.g., floor, roof, ramp, or runway) where there is no wall or guardrail system at least 39 inches high.
- 15.17.23 Walking/working surface- Any surface, whether horizontal or vertical, on which an employee walks or works, including but not limited to floors, roofs, ramps, bridges, runways, formwork, and concrete reinforcing steel. Does not include ladders, vehicles, or trailers on which employees must be located to perform their work duties.
- 15.17.24 Warning line system- A barrier erected on a roof to warn employees that they are approaching an unprotected roof side or edge and which designates an area in which roofing work may take place without the use of guardrail or safety net systems to protect employees in the area.

16.0 Scaffolding (Included in Fall Protection Program)

- 16.1.1 When employees must conduct construction work above the ground and away from solid platforms, scaffolds may be appropriate. The following list provides guidelines for using small scaffolds. Larger scaffolds must be designed and erected in accordance with applicable standards.
- 16.1.2 Ensure that scaffold anchors are sound, rigid, and capable of supporting the maximum intended load without shifting.



***NOTE:** Scaffolds and their components should be capable of supporting at least four times their maximum load.*

- 16.1.3 For freestanding, mobile scaffolds, the height should not exceed four times the minimum base dimension. If workers are riding the scaffolding, however, the base dimension should be at least one half the heights.
- 16.1.4 Do not use unstable objects such as barrels, boxes, bricks, or blocks to support scaffolds or planks.
- 16.1.5 Keep floors free of debris where mobile scaffolds are used.
- 16.1.6 Lock scaffolds with wheels into position.
- 16.1.7 Install guardrails, midrails, or toeboards on the open sides and ends of platforms that are more than 4 feet above the ground or floor level. Use lifelines for scaffolds that are more than 10 feet off the ground.
- 16.1.8 Either overlap multiple planking and platforms by 12 inches or secure them to ensure stability.

***NOTE:** Planks must extend over end supports between 6 and 18 inches.*

- 16.1.9 Secure scaffolds to permanent structures with anchor bolts or other means.
- 16.1.10 Do not load scaffolds in excess of their maximum load limits.
- 16.1.11 Repair damaged scaffolds immediately.
- 16.1.12 Do not work on scaffolds in high winds or during storms.
- 16.1.13 Remove ice or snow from scaffolds and apply sand to the wood before conducting work in winter weather.
- 16.1.14 Do not allow tools, equipment, or other debris to accumulate on scaffolds.
- 16.1.15 Dismantle and remove scaffolds when they are no longer needed. Do not use temporary scaffolding as a permanent installation.

17.1 Trenching

- 17.1 29 CFR 1926.651 “Excavation Requirements”
 - 17.1.1 Controls the trenching and excavation requirements for construction (excluding tunnels)
 - 17.1.2 Provides requirements for employee entrance, working environment, and egress to/from open surface trenches and excavations
- 17.2 Pre-excavation requirements
 - 17.2.1 The estimated location of utility installations such as sewer, telephone, fuel, electric, water lines, or other underground installations that

reasonably may be encountered during excavation work shall be determined prior to opening an excavation

17.2.2 Utility companies or utility locator should be contacted to precisely locate such utilities

17.2.3 Excavation may proceed with CAUTION if:

17.2.3.1 Utility Company/Locator can not be located or contacted

17.2.3.2 Utility Company/Locator can not locate utility

17.3 Excavation opening requirements

17.3.1 When excavating operations approach the location of underground utilities, the exact location shall be determined by safe and acceptable means

17.4 While excavation is open, underground installations shall be protected, supported, or removed as necessary to safeguard employees

17.5 Excavation access/egress

17.5.1 Structural ramps/runways used for access/egress

17.5.2 If constructed of two or more members, shall have members connected together

17.5.3 if constructed of two or more members, shall have members of uniform thickness

17.5.4 Cleats or other connections shall be attached to bottom of runways/ramps

17.5.5 Runways/ramps shall be anchored to prevent movement or slipping

17.5.6 Ladders

17.5.6.1 Shall be of proper design

17.5.6.2 Shall be secured from movement or slippage

17.5.6.3 Shall extend 3' above top of excavation

17.6 Employee protection

17.6.1 Employees exposed to public vehicular traffic shall be provided with and wear vest or other suitable garments marked with high visibility materials

17.6.2 No employee shall be permitted underneath loads handled by digging or lifting equipment

- 17.6.3 When mobile equipment is operated near excavation; barricades, hand and mechanical signals, or stop logs shall be used to protect employees in excavations.
- 17.7 Hazardous atmospheres
 - 17.7.1 Excavations of greater than 4' depth that are located in or near hazardous materials, liquids, or gases shall be tested for the presence of hazardous atmospheres prior to employee entry
 - 17.7.2 An atmosphere shall be considered hazardous if the level of atmospheric contaminants exceeds 20% of the PEL
 - 17.7.3 Excavation of greater 4' depth shall be regularly tested for oxygen deficiency (less than 19.5% oxygen)
 - 17.7.4 Ventilation and respiratory protection shall be provided where hazardous atmospheres are encountered
- 17.8 Emergency rescue equipment
 - 17.8.1 Where hazardous atmospheres exist or may be expected to occur, the following rescue equipment shall be readily available for use:
 - 17.8.1.1 Safety Harnesses and lines
 - 17.8.1.2 Basket stretcher
 - 17.8.1.3 Breathing apparatus equipment
 - 17.8.1.4 Employees entering bell-bottomed holes shall wear harness and life line protection
 - 17.8.1.5 Employees shall not work in excavations where there is accumulated water unless adequate safety precautions (shoring, etc.) have been taken
- 17.9 Stability of adjacent structures
 - 17.9.1 Excavations near structures or buildings shall be protected by shoring or other means to assure stability of the affected structure
 - 17.9.2 Diversion ditches, dikes, or other suitable means shall be provided to prevent surface water intrusion where natural drainage has been interrupted
 - 17.9.3 Excavations near foundation footings, sidewalks, pavement, or other appurtenant structures shall be protected by underpinning or other suitable means to maintain stability
- 17.10 Stability of excavated materials and excavation walls

17.10.1 Excavated materials shall be kept a minimum of 2' from the edge of excavations or by the use of retaining devices

17.10.2 Excavated materials may require further clearance from excavations in accordance with soil types (see table)

17.10.3 Excavation wall slopes or other wall protection shall be used in accordance with soil type, moisture levels, and other criteria as specified in the soil tables (see table)

17.11 Figures associated with trenching are depicted below

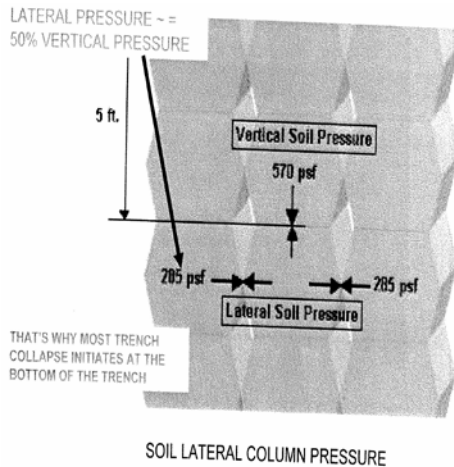
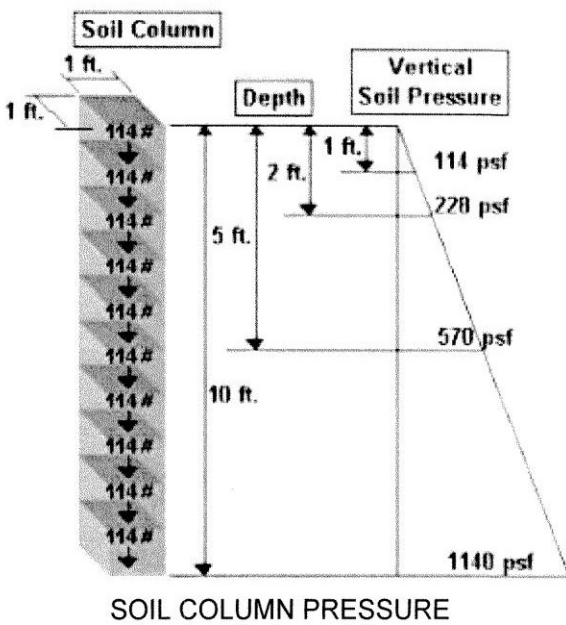

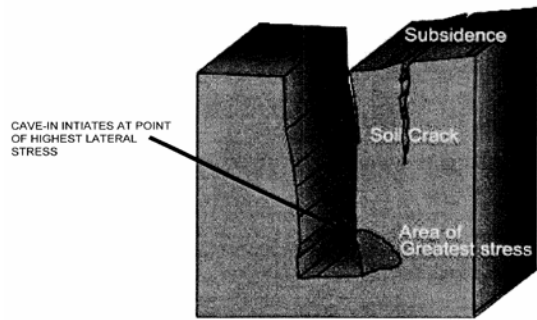

ANATOMY OF A CAVEIN - ONSET

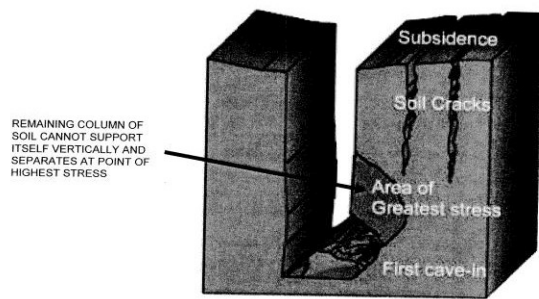

ANATOMY OF A CAVEIN - GROWTH STAGE

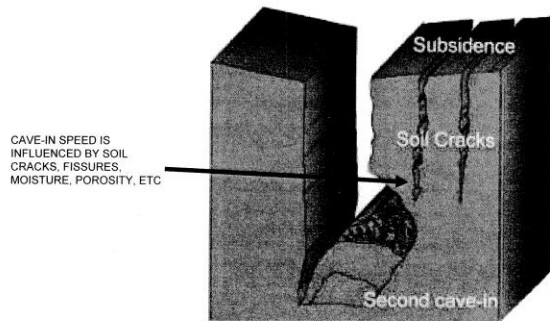

ANATOMY OF A CAVEIN - FULLY DEVELOPED

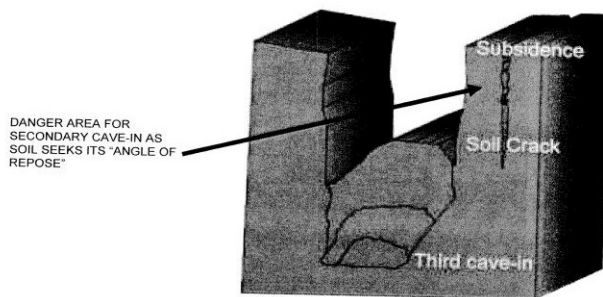





ANATOMY OF A CAVEIN - COMPLETION

- There is a "natural angle of repose" for soil. It means that over time the soil will go to a certain slope (usually its natural angle).

- Excavation protection is a function of soil type

OSHA categorizes soil and rock deposits into four types as follows:

- A. STABLE ROCK is a natural solid mineral matter that can be excavated with vertical sides and remain intact while exposed. Most of the time it is identified by a rock name such as granite or sandstone.
- B. TYPE 'A' SOILS are cohesive soils with an unconfined compressive strength of 1.5 tons per square foot or greater. These types of soils are often clay, silt clay, sandy clay, clay loam and in certain cases, silty clay loam and sandy clay loam.
- C. TYPE 'B' SOILS are cohesive soils with an unconfined compressive strength greater than 0.5, but less than 1.5 tons per square foot. Examples include angular gravel silt, silt loam, and/or previously disturbed soils
- D. TYPE 'C' SOILS are cohesive soils with an unconfined compression strength of 0.5 tons per square foot or less. Granular soils like gravel, sand and loamy sand, submerged soil, soil from which water is freely seeping, and submerged rock that is not stable fall into the Type 'C' soil category.

	Option	Type A	Type B	Type C
	Simple Slope	Yes	Yes	Yes
	Short-term Slope	Yes	No	No
	Simple Bench	Yes	Yes	No
	Multiple Bench	Yes	Yes/No*	No
	Slope with Shoring/Shielding	Yes	Yes	Yes

*Multiple bench allowed only in cohesive Type B soil

TRENCH SLOPES VS. SOIL TYPE

Slope Configurations

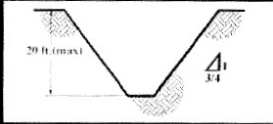

**SIMPLE SLOPE - GENERAL
TYPE A SOIL**
20 ft. or less in depth
maximum allowable slope of 3/4:1

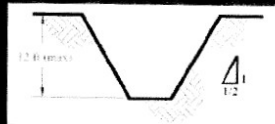

**SIMPLE SLOPE - SHORT TERM*
TYPE A SOIL**
12 ft. or less in depth
maximum allowable slope of 1/2:
*open 24 hours or less

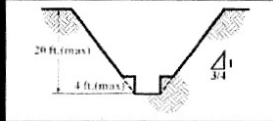

**SINGLE BENCH
TYPE A SOIL**
20 ft. or less in depth
maximum allowable slope of 3/4:1
maximum bench height 4 ft.

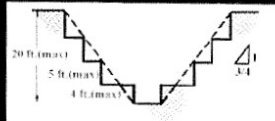

**MULTIPLE BENCH
TYPE A SOIL**
20 ft. or less in depth
maximum allowable slope of 3/4:1
maximum bench heights shown

TRENCH SLOPES CONFIGURATIONS - PG 1



**UNSUPPORTED VERTICALLY
SIDED LOWER PORTION
TYPE A SOIL**
8 ft. or less in depth
maximum vertical side of 3-1/2 ft

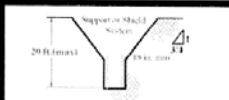

**SUPPORTED/SHIELDED
VERTICALLY SIDED LOWER
PORTION - TYPE A SOIL**
20 ft. or less in depth
maximum allowable slope of 3/4:1
support/shield system must extend
at least 18 in. above vertical side

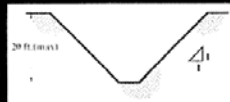

**SIMPLE SLOPE
TYPE B SOIL**
20 ft. or less in depth
maximum allowable slope of 1:1

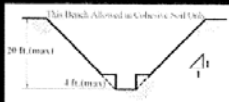

**SINGLE BENCH
TYPE B SOIL**
20 ft. or less in depth
maximum allowable slope of 1:1
maximum bench height 4 ft.

TRENCH SLOPES CONFIGURATIONS - PG 2

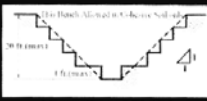

**MULTIPLE BENCH
TYPE B SOIL**
20 ft. or less in depth
maximum allowable slope of 1:1
maximum bench heights shown

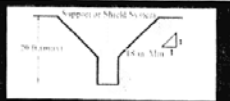

**SUPPORTED/SHIELDED
VERTICALLY SIDED LOWER
PORTION - TYPE B SOIL**
20 ft. or less in depth
maximum allowable slope of 1:1
support/shield system must extend
at least 18 in. above vertical side



**SIMPLE SLOPE
TYPE C SOIL**
20 ft. or less in depth
maximum allowable slope of 1-1/2:1

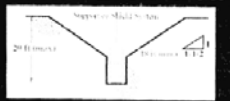

**SUPPORTED/SHIELDED
VERTICALLY SIDED LOWER
PORTION - TYPE C SOIL**
20 ft. or less in depth
maximum allowable slope of 1-1/2:1
support/shield system must extend
at least 18 in. above vertical side

TRENCH SLOPES CONFIGURATIONS - PG 3

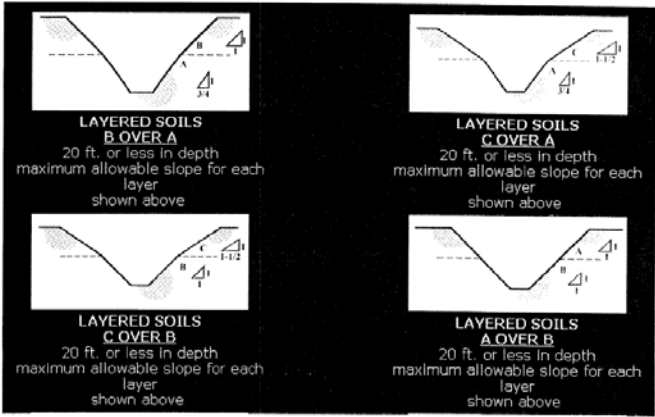

TRENCH SLOPES CONFIGURATIONS – PG 4

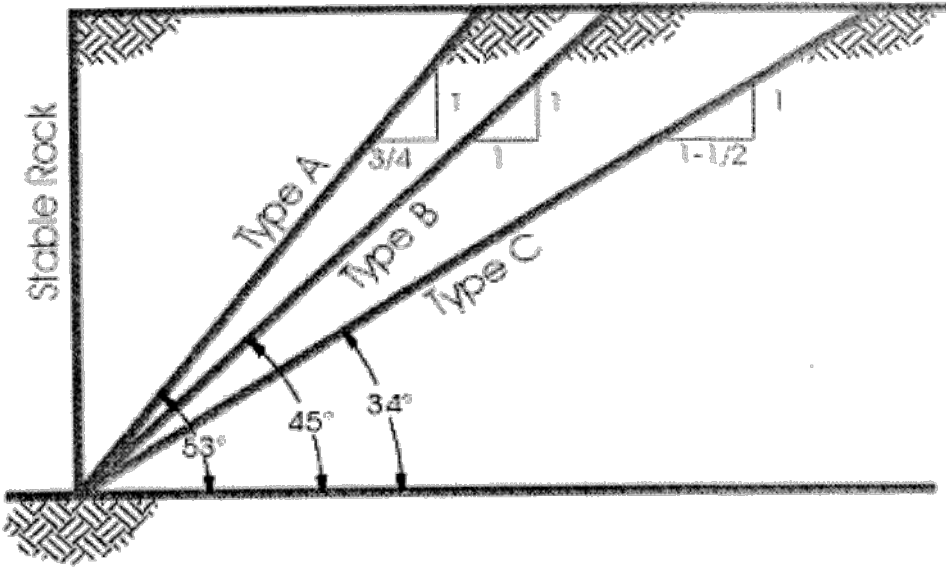
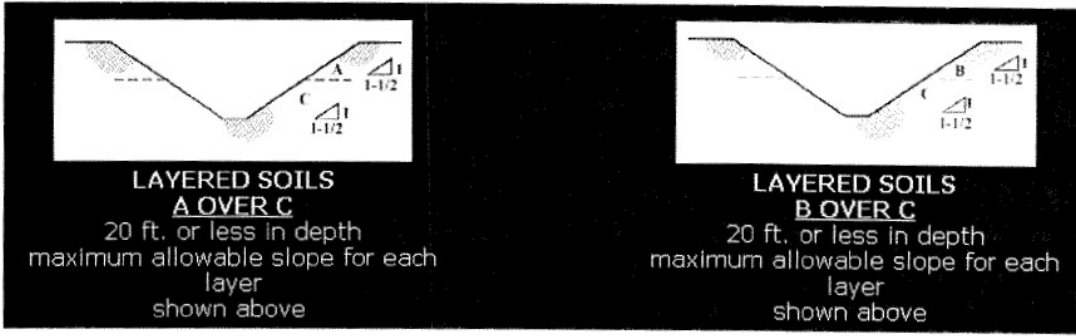

Trench slope angles

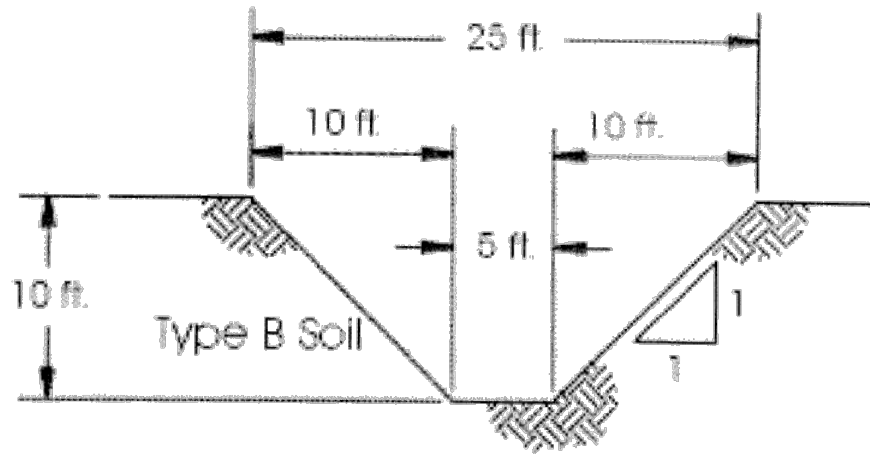

Trench typical dimensions

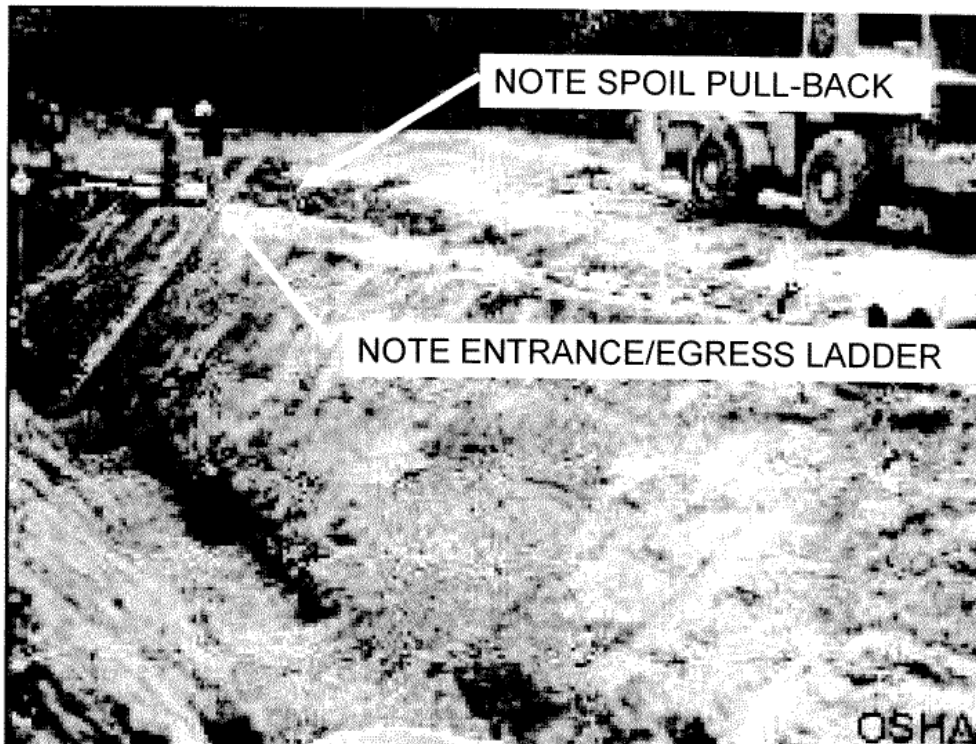

Typical sloped trench

Shoring System Components

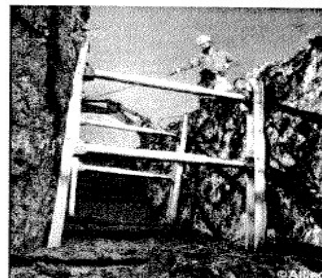
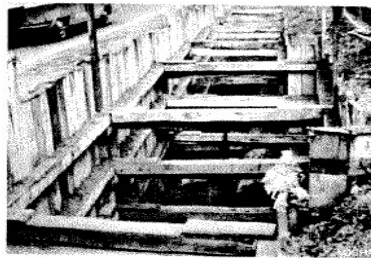
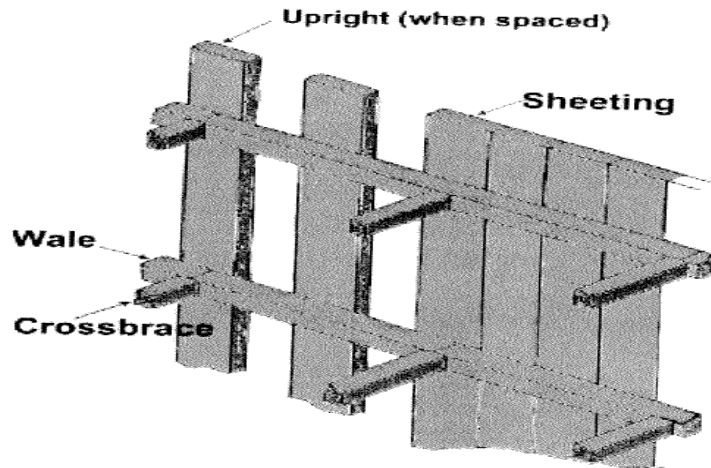

TRENCH SHORING EXAMPLES

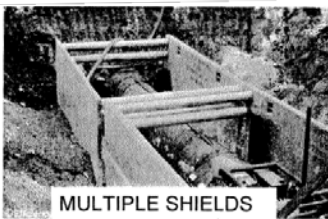

MULTIPLE SHIELDS

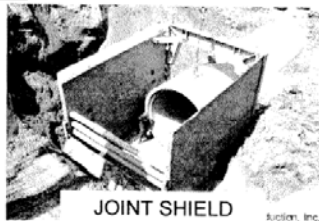

JOINT SHIELD

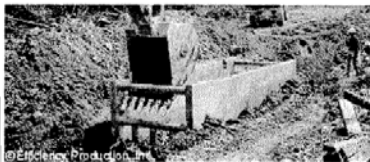

SLIDING SHIELD



SHIELD TRANSPORT

VII. Confined Space

1.0 Policy

- 1.1 It is the policy of Texas A&M International University (TAMIU) that any individual entering into a confined space on TAMIU property will do so in accordance with the procedures outlined in the Confined Space Program and OSHA regulation 29 CFR 1910.146
- 1.2 The purpose of this program is to identify, document, evaluate, and properly label all confined spaces on the TAMIU campus, and to allow only trained and authorized personnel to enter such spaces.
- 1.3 This program also provides guidelines for all entries into confined spaces on TAMIU grounds and facilities, so that they can be accomplished in a safe and healthful manner.

2.0 Reason

- 2.1 Confined spaces can present unique and very dangerous safety situations to those that must enter.
- 2.2 By their definition, confined spaces can typically be difficult to enter and exit.
- 2.3 Confined spaces can also contain atmospheric gases and other hazards that make them particularly hazardous for personnel entry.
- 2.4 The Confined Space Program involves training, signage and safety equipment, as appropriate; to be sure that employees are vigilant in their work in and around confined spaces and do not inadvertently or innocently enter into a confined space. The potential for serious injury is high, thus it is important that TAMIU employees who may enter any confined space, work with their department and EHS to ensure that all necessary safety precautions are considered and taken.

3.0 Definition and Locations

- 3.1 A confined space is defined as:
 - 3.1.1 A space with the existence of all of the following conditions:
 - 3.1.1.1 Large enough and so configured that an employee can bodily enter and perform assigned work. Has limited or restricted means for entry or exit.
 - 3.1.1.2 Is not designed for continuous employee occupancy.

3.2 Locations

3.2.1 TAMIU has undertaken the effort to identify and maintain a detailed listing that permanently identifies locations meeting the criteria for a confined space.

3.2.2 In addition, TAMIU will identify and label Permit Required Confined Spaces (PRCS). Only appropriately trained individuals may enter PRCS.

4.0 Examples of a Confined Space

4.1 Some examples of confined spaces at TAMIU include manholes, boilers, tanks, vats, sewer pipelines, and vaults without existing general ventilation.



5.0 Training

5.1 All employees that participate or have duties in the Confined Space Program will receive training to ensure that each individual has the understanding, knowledge and skills necessary to safely perform activities in the confined space.

5.2 The level of training will be in accordance with the Confined Space Program.

6.0 Work in a Confined Space

6.1 All work in a confined space must be performed in accordance with the Confined Space Program. To review a copy of the Program, please contact EH&S.

6.2 If you are unsure about whether you will be entering a confined space, you must **STOP** and contact your supervisor or EHS, before entering the area.

END OF SECTION

VIII. Fire & Life Safety

Fire and life safety at Texas A&M International University (TAMIU) is governed by federal, state and local, standards including System Regulations and University Rules and University Standard Administrative Procedures. Ultimate jurisdiction for fire safety lies with the Texas State Fire Marshal and with the local Authority Having Jurisdiction (AHJ) as designated by the President of Texas A&M International University. The President has designated the Safety/Risk Manager for Fire and Life Safety in the office of Environmental Health and Safety to be the local AHJ and to be responsible for the day to day fire prevention, inspection, and program oversight. However, each and every individual, whether faculty, staff, student, or visitor on our campus shares a role in fire safety.

TAMIU is committed to providing a safe environment for building occupants and emergency response personnel.

1.1 Program Requirements

- 1.2 The basis for the fire and life safety program at TAMU is provided for by TAMU System regulation - 24.02.02 *Health and Safety Program* <http://www.tamus.edu/offices/policy/policies/pdf/24-02-02.pdf>.

2.0 Applicable Codes & Standards

- 2.1 The Texas State Fire Marshal's Office has adopted the National Fire Protection Association *Life Safety Code*© and all referenced codes and standards as the primary guide for fire and life safety. It is important to note that this code is not all inclusive, is not a building code, and that other codes and standards may also apply. Some of these include, but are not limited to:
 - 2.1.1 International Building Code
 - 2.1.2 International Fire Code
 - 2.1.3 International Mechanical Code
 - 2.1.4 Americans with Disabilities Act
 - 2.1.5 Texas Accessibility Standards Act

3.0 Fire and Life Safety Program

- 3.1 The fire and life safety program at TAMIU involves numerous activities, programs, and procedures to help ensure that our campus is a safe place to work, live, and play. These program areas include fire prevention, fire suppression, emergency preparedness, preplanning, education, and response. The following information is provided as a general guideline for activities associated with fire and life safety. Additional information may be obtained by contacting Environmental Health and Safety or by going to our website for the latest information. Links are provided throughout this document.

4.0 Appliances

- 4.1 An appliance can be defined as any instrument or piece of equipment or device designed for a particular use and powered by electricity. (i.e. computers, copy machines, refrigerators, freezers, space heaters etc.) Use the following guidelines when using appliances on campus.
 - 4.1.1 Always use appliances that are UL or FM labeled.
 - 4.1.2 Adequate space should be given around appliances to allow for air circulation.
 - 4.1.3 Clothes dryers should have the lint removed after each load and excess build up of lint around the dryer should be cleaned regularly.
 - 4.1.4 Large appliances such as refrigerators and freezers should be plugged directly into wall outlets.
 - 4.1.5 Frequently inspect the electrical connection of appliances to ensure a good connection with the receptacle
 - 4.1.6 Frequently inspect the condition of appliances. If appliances begin to spark or produce an electrical smell, turn power off immediately and discontinue using the appliance.

5.0 Arson

- 5.1 If arson is suspected, no matter how small the incident, contact the University Police Department or Environmental Health & Safety. Do not alter the fire scene in any way, unless you are trying to extinguish a live fire. The UPD will investigate any possible arson.

5.2 Building Evacuations/Drills

- 5.3 To ensure that building occupants are prepared for an emergency evacuation, drills must be conducted on a regular basis. Evacuation drills may be used to vacate a building for several reasons such as fires, gas leaks, chemical spills, bomb threats or other similar emergencies and emphasis should be placed on orderly evacuation rather than on speed.

- 5.4 These drills should:
- 5.4.1 Involve all occupants. Everyone should leave the building when the fire alarm sounds.
 - 5.4.2 Occupants should close (not lock) doors as they leave the work area, provided this does not violate security procedures. Items that require security may be placed in a locking file cabinet or desk drawer on the way out.
 - 5.4.3 Building Emergency Coordinators should check all rooms and close doors on their way out.
 - 5.4.4 All building occupants should gather in the preplanned meeting place.
- 5.5 Upon completion of the drill, an evaluation of the drill shall be conducted and filed with EHS to identify any areas for improvement and to document the drill.

6.0 Candles & Incense

- 6.1 The use of candles, incense burners, oil lamps and other items are governed by a University [SAP 24.01.99.L1.03 Restriction on Candles](#). General guidelines include:
- 6.1.1 Candles, incense burners, oil lamps or other personal items that have open flames or that smolder, are prohibited in work areas (individual or group), conference rooms, restrooms, etc. in all campus buildings. This restriction applies to such items regardless of whether the item has been lit.
 - 6.1.2 Candles, flame effects, or pyrotechnics used for banquets, ceremonies, science demonstrations, theatrical productions, indoor fireworks or other entertainment are addressed in a separate SAP [24.01.99.L1.05: Use of Pyrotechnics or Flame Effects](#).
 - 6.1.3 This use of candles does not apply to such devices used in the course and scope of University or Agency sponsored research or activities necessary to conduct business operations. If the burning of a candle(s) is permitted under the above mentioned exemption, the candle must be in a glass or similar container and kept away from combustible materials.
 - 6.1.4 Students living in residence halls and University-owned apartments are governed by similar but separate rules as set forth by Housing and Residence Life.

7.0 Combustible Storage

- 7.1 One of the most common violations of general fire safety practices is that of improper or excessive storage of combustible material. By storing excess combustible materials improperly, employees not only increase the potential for

having a fire, they increase the potential severity of a fire. To reduce the hazards associated with combustible storage, follow these guidelines:

- 7.1.1 Eliminate excess combustible materials such as paper and cardboard.
- 7.1.2 Never store combustible materials in hallways, stairwells, or mechanical rooms.
- 7.1.3 When stacking combustible materials, leave at least 24” from the top of the storage to the ceiling

8.0 Compressed Gas Cylinders

8.1 Compressed gas cylinders, in service or in storage, shall be adequately secured (chained) to prevent falling or being knocked over. Ropes, cords, rubber and other combustible material are not approved for this purpose. Compressed gas cylinders shall have their caps in place except when they are in use or are being serviced or filled.

9.0 Construction and Renovation

9.1 EHS serves the role of Authority Having Jurisdiction (AHJ) for all TAMIU owned property and any buildings or structures on that property. All proposed construction, structural changes, or changes in the use, or any change effecting egress from a space within a building on the TAMIU campus, regardless of facility ownership, must be reviewed and approved by the EHS and Physical Plant in order to address fire and life safety issues.

10.0 Decorations

10.1 When decorating your area, there are several things that you must be aware of:

- 10.1.1 Never hang anything from fire sprinkler piping or heads
- 10.1.2 Never obstruct fire alarm devices
- 10.1.3 Any combustible decorations such as curtains or drapes must be of a fire resistant material
- 10.1.4 Never obstruct an exit or the visibility thereof
- 10.1.5 Never staple or tack light strings
- 10.1.6 Decorations should not be placed in exit corridors or stairways

10.2 Holiday Decorations

10.2.1 Holiday decorations are often fire hazards if not utilized properly. Follow these guidelines to improve fire safety during the holidays:

- 10.2.1.1 Do not use live cut Christmas trees in University buildings. Use an artificial tree that is fire resistant.

- 10.2.1.2 Do not place holiday decorations where they may block emergency egress (e.g., stairways, corridors, near doors, etc.)
- 10.2.1.3 Only use decorations that are fire retardant.
- 10.2.1.4 Practice good housekeeping by minimizing paper and other combustible decorations.
- 10.2.1.5 Avoid using extension cords. If you must use an extension cord, use a heavy gauge cord and place it in plain view. Make sure the cord does not pose a tripping hazard.
- 10.2.1.6 Use FM or UL labeled electrical decorations.
- 10.2.1.7 Do not light candles or use other decorations with open flames
- 10.2.1.8 Turn off lights when the room is unoccupied.

11.0 Electrical Safety

11.1 Extension Cord and Power-Strip Use

- 11.1.1 Many times it is necessary to use extension cords or power strips (surge protectors) to reach a work area or to provide additional outlets. It is important not to overload outlets, protect cords, and follow the manufacturer's recommendation. Additionally, the following guidelines should be used while utilizing these items:
 - 11.1.2 Extension cords are for temporary use (defined as an 8-hour work day or less)
 - 11.1.2.1 Unplug and properly store cords when not in use
 - 11.1.2.2 Install permanent code compliant wiring for long term use
 - 11.1.3 Extension cords or power strips must be plugged directly into a wall receptacle – no daisy chaining is permitted
 - 11.1.4 Extension cords should be used for portable equipment
 - 11.1.5 Extension cords and power strips should be examined regularly for damage and removed from service if damage is found
 - 11.1.6 Extension cords and power strips should be UL listed
 - 11.1.7 Extension cords shall not be run above ceiling or under carpet or other similar materials

11.2 Electrical Panel Access

- 11.2.1 A working space of not less than 30" wide (or width of equipment), 36" deep and 78" high shall be provided in front of electrical service equipment. No storage shall be permitted within this designated work space.

12.0 Emergency Access and Egress

- 12.1 Emergency access and egress are critical during an emergency situation such as a fire. During a fire, timing and quick response are essential to save lives and property. Effective emergency access ensures that fire trucks can reach a building in time to extinguish the fire. Unobstructed emergency egress ensures that building occupants can exit a building to safety.

12.2 Emergency access helps ensure that facilities and equipment remain available and unobstructed at all times to ensure effective fire detection, evacuation, suppression, and response. Emergency egress is defined as a continuous and unobstructed way to travel from any point in a public building to a public way. A means of egress may include horizontal and vertical travel routes, including intervening rooms, doors, hallways, corridors, passageways, balconies, ramps, stairs, enclosures, lobbies, courts, and yards.

12.3 Corridors, Stairways, and Exits

12.3.1 An exit corridor and/or stairway is a pedestrian pathway that allows direct access to the outside of a building and/or allows access to a building entrance and subsequent pathways to the outside of a building (i.e., an exit corridor is the quickest, easiest, and most direct pathway for leaving a building). Because exit corridors or passageways are the primary means of egress during an emergency, employees must follow the safety guidelines outlined in this section.

12.3.2 Follow these guidelines to promote safe evacuation in corridors, stairways, and exits:

12.3.2.1 Keep all means of egress clean, clutter-free, and unobstructed

12.3.2.2 Do not place hazardous materials or equipment in areas that are used for evacuation

12.3.2.3 Do not use corridors or stairways for storage or office/laboratory operations

12.3.2.4 Do not place locks, chains, or other devices that can defeat or obstruct an exit without prior written permission from EHS

12.3.2.5 Corridors may not be used as an extension of the office or laboratory

13.0 Flammable and Combustible Liquids

13.1 Definitions:

13.1.1 Flash Point – The lowest temperature at which vapors above a volatile combustible substance will ignite in air when exposed to a spark or flame.

13.1.2 Flammable Liquid - Any liquid that has a closed cup flash point below 100[°]F.

12.1.3 Combustible Liquid – Any liquid that has a closed cup flash point at or above 100[°]F.

13.2 Flammable Liquids are further classified as Class I, Class IA, IB and IC liquids. Combustible liquids are further classified as Class II, Class III, Class IIIA and Class IIIB liquids. You can identify if you are working with flammable or

combustible materials by referencing the flash point on the product label or MSDS sheet.

- 13.3 When working with these materials, precautions should be taken to prevent the ignition of flammable vapors by sources such as the following: open flames, hot surfaces, radiant heat, smoking, cutting and welding, sparks, static electricity. Make sure you are in a well ventilated and/or exhausted area to allow dangerous vapors to dissipate or escape the area. Only acceptable containers that meet the requirements set forth in the Flammable and Combustible Liquids Code published by the National Fire Protection Association (NFPA) should be used with flammable and combustible liquids. The allowable size of these containers is dependant upon the class of liquid and the container type and is specified in the Flammable and Combustible Liquids Code (NFPA 30). Flammable and combustible liquids should be stored inside a flammable liquids storage cabinet with an aggregate amount of liquid stored in an individual storage cabinet not to exceed 120 gallons.

14.0 Fire Detection and Notification

- 14.1 Most occupied buildings on the TAMIU campus have automatic fire detection/notification systems installed in them. These systems are monitored at the Central Plant and the University Police Department. These systems utilize several different types of detection devices including heat, flame, and smoke detectors, relays from suppression/extinguishing systems, and manual pull stations to activate the notification portion of the system.

14.2 Detection Devices

14.2.1 Heat Detectors

- 14.2.1.1 Heat detectors respond to the convected energy in hot smoke and fire gases (i.e., heat). Heat detectors are normally located in laboratories, mechanical rooms, storage areas, break rooms, and areas that could produce high levels of dust, steam, or other airborne particles.

14.2.2 Smoke Detectors

- 14.2.2.1 Smoke detectors respond to the solid and liquid aerosols produced by a fire (i.e., smoke). Since smoke detectors cannot distinguish between smoke particles and other particles such as steam, building occupants must be aware of detector locations and be considerate when working around them. Smoke detectors are normally found in exit corridors, office areas, assembly areas, and sleeping areas.

14.2.3 Flame Detectors

14.2.3.1 Flame detectors respond to the presence of a flame. Flame detectors may be found in specific areas where a fire will develop rapidly and the hazard is greater than what is expected in normal locations within buildings such as chemical storage rooms. These devices are most commonly used in conjunction with a fire extinguishing system.

14.2.4 Manual Pull Stations

14.2.4.1 Manual pull stations, when activated, will initiate the buildings fire alarm notification system. Pull stations are generally located near exit stairways, near building exits, or in long corridors. Occupants should be familiar with the location of these devices should one need to initiate a building evacuation.

14.3 Building Notification

14.3.1 The building notification system may consist of horns, bells, speakers, strobes, or a combination of these devices. It is important to maintain a clear line of sight to any of these devices to ensure they can be seen and/or heard.

15.0 Fire Doors

15.1 Fire doors serve as a barrier to limit the spread of fire and restrict the movement of smoke. Unless these doors are held open and released by the building fire alarm system fire doors should remain closed at all times. Do not tamper with fire doors or block them with equipment, potted plants, furniture, etc.

15.2 Fire doors are normally located in stairwells, corridors, and other areas required by Fire Code. The door, door frame, locking mechanism, and closure are rated between 20 minutes and three hours. A fire door rating indicates how long the door assembly can withstand heat and a water hose stream. All fire doors will have a label affixed to the door indicating the manufacturer, rating, serial # of the door and other information. It is important to not remove, paint, or in any way damage or destroys the label.

15.3 For your safety and to maintain the integrity of fire doors there are several important items to remember:

15.3.1 Know which doors are fire doors and keep them closed to protect building occupants and exit paths from fire and smoke.

15.3.2 Never block a fire door with a non-approved closure device such as a door stop, blocks of wood, or potted plant.

- 15.3.3 For fire doors with approved closure devices, make sure that nothing around the door can impede the closure.
- 15.3.4 Never alter a fire door or assembly in any way. Simple alterations such as changing a lock or installing a window can lessen or completely void the fire rating of the door.
- 15.3.5 Doors to offices, laboratories, and classrooms help act as smoke barriers regardless of their fire rating. Keep these doors closed whenever the room is unoccupied.
- 15.3.6 A closed door is the best way to protect your path to safety from the spread of smoke and fire.

16.0 Fire Extinguishers

- 16.1 Fire Extinguishers, when used properly, play a vital role in containing and/or extinguishing small fires. Portable fire extinguishers are designed to be used on small, contained fires, by properly trained individuals. Lives could be saved, and property damage reduced, when fire extinguishers are used correctly.
- 16.2 Know the location of the closest extinguisher. A quick response is crucial to effectively put out a fire. You should not have to travel any farther than 75 feet to get to an extinguisher. This distance may be reduced in labs and other high hazard areas.
- 16.3 There are five classifications for fires. These are:
 - 16.3.1 **Class A:** Fires involving ordinary combustibles, such as paper, wood, plastic, cloth, and trash.
 - 16.3.2 **Class B:** Fires that involve flammable or combustible liquids, such as gasoline, solvents, oil, paint, and thinners.
 - 16.3.3 **Class C:** Fires that involve energized electrical equipment or appliances.
 - 16.3.4 **Class D:** Fires involving flammable metals, such as magnesium and sodium.
 - 16.3.5 **Class K:** Fires that involve cooking media, such as vegetable oils.
- 16.4 There are fire extinguishers designed for each type of fire. Some extinguishers can be used on more than one type of fire.
- 16.5 Class A extinguishers are to be used only on Class A fires. This extinguisher contains only water and compressed air and is not to be used on B, C, D, or K fires.
- 16.6 Carbon Dioxide extinguishers are recommended for Class B and C fires. Halon or other similar type fire extinguishers are also rated to be used on B and C fires.

- 16.7 Dry Chemical extinguishers come in two types. One type is rated for B-C fires, and the other is rated for A-B-C fires. The ABC or multipurpose extinguisher is the most common extinguisher found on the TAMU Campus.
- 16.8 Class D extinguishers are specialized to be used only on flammable metals. Never attempt to extinguish a Class D fire with anything other than a CLASS D extinguisher.
- 16.9 Class K extinguishers are designed to be used on flammable cooking oils. They are to be used in conjunction with a commercial fire suppression system.
- 16.10 There is no extinguisher that is designed to be used on all types of fires. It is important to know your fire extinguisher and its limitations
- 16.11 Inspection and Maintenance
- 16.11.1 EHS conducts regular inspections of fire extinguishers. The department also services extinguishers that have been used, and also performs the required maintenance and testing of extinguishers. Once used, fire extinguishers must be serviced or replaced. If an extinguisher has been used, is missing, needs to be relocated, or any other type of service, contact EHS for assistance.
- 16.12 Portable fire extinguishers are located throughout buildings across the campus. They are installed according to National Fire Protection Association codes and standards. Extinguishers are readily accessible in hallways, near exits, and in areas containing high fire hazards. Never block access to an extinguisher.
- 16.13 Using an extinguisher
- 16.13.1 To use a fire extinguisher you must remember the *PASS*-word.
- 16.13.1.1 **P**ull the ring-pin (held in place by a plastic seal) to “unlock” the operating lever.
- 16.13.1.2 **A**im the nozzle at the base of the fire
- 16.13.1.3 **S**queeze the lever completely
- 16.13.1.4 **S**weep the extinguishing agent from side to side until the fire is extinguished
- 16.14 The normal operating distance of different extinguishers will vary considerably. A dry chemical extinguisher will have a discharge range of 8-10 feet, while a Carbon Dioxide extinguisher may only reach 5-6 feet.
- 16.15 Remember:
- 16.16.1 Only attempt to extinguish small, contained fires

- 16.16.2 Make sure you are properly trained, and capable of fighting the fire
- 16.16.3 Be certain that you have the correct extinguisher for the type of fire
- 16.16.4 Always keep a clear, unobstructed exit
- 16.16.5 Never turn your back on a fire
- 16.16.6 Fires may re-ignite, so be prepared

16.16 Training

- 16.16.1 Learn how to use a fire extinguisher before an emergency occurs. EHS provides hands on training in the use of portable fire extinguishers. Participants will learn about the different types of extinguishers, how to use each type, and will have the opportunity to extinguish a real fire. Make sure you have the correct extinguisher for the type of fire to be extinguished. All extinguishers have a label that states what type of fire they can be used on and this will be explained to further assist occupants in selecting the proper type of extinguisher. For information or to register for a class, contact EHS.

17.0 Fire Hydrants

- 17.1 Fire hydrants are located throughout the campus and play a vital role in fire suppression operations. It is important to maintain a clear path to all hydrants and allow clear distances around hydrants to allow uninhibited operation should an emergency occur. It is also important that vehicles are not parked within 15 feet of fire hydrants or other fire safety equipment.

18.0 Fire Lanes

- 18.1 A fire lane is an area designated for emergency personnel only. It allows them to gain access to building and/or fire protection systems. Parking in or blocking any fire lane is prohibited.

19.0 Fire and Life Safety Inspections

- 19.1 Fire and life safety inspections are conducted at least annually in TAMIU facilities. The goal of these inspections is to help identify potentially unsafe practices and conditions in TAMIU facilities. These are not surprise inspections. EHS will notify administration prior to inspecting a facility. We want to work with building occupants to help ensure a fire safe environment in which to work.
- 19.2 Some of the items that our inspectors will be looking for include but are not limited to:
 - 19.2.1 Access to the facility for emergency responders
 - 19.2.2 Means of egress and verifying that egress components are unobstructed and in working condition

- 19.2.3 Electrical safety (extension cords, power strips etc.)
- 19.2.4 Storage of materials (24" from ceiling, 18" from sprinkler heads)
- 19.2.5 General Housekeeping
- 19.2.6 Presence of ignition sources

19.3 At the conclusion of the inspection a report is generated and sent back to the proper directors, supervisors or administrators to be disseminated to the building occupants for them to take necessary actions to remediate any inspection deficiencies.

19.4 In addition to regular facility fire and life safety inspections, EHS conducts inspections in our residence halls and apartment complex as well.

20.0 Fire Prevention

20.1 Fire Safety is everyone's responsibility. In fact you are your office's best fire inspector. The following section will provide ways you can help prevent fires.

20.1.1 Fire prevention starts with good house keeping. Loose papers, trash and other combustible items such as cardboard boxes are a fuel source for fire. If these combustible items are stored neatly and properly the risk of fire can be greatly reduced. Here are some things to be mindful of when it comes to combustible items:

- 20.1.1.1 Never store combustible items within 24 inches of the ceiling.
- 20.1.1.2 If you have sprinkler heads in your building keep ALL storage at least 18 inches below the sprinkler heads.
- 20.1.1.3 Keep combustible items away from electrical sources that may produce heat and/or sparks. (Outlets, multiple adapters, etc.)
- 20.1.1.4 Keep quantities of combustible items to a minimum.
- 20.1.1.5 Never store combustible items in an exit corridor or stair enclosure.
- 20.1.1.6 Combustible items should not be stored in mechanical equipment rooms or electrical rooms.

21.0 Fire Reporting

21.1 If you discover a fire in a facility on campus you should

21.1.1 Locate and activate the nearest manual pull station (Pull stations should be located near building exits) to initiate a building evacuation

21.1.2 Call 9-911 from any campus phone or 911 if calling from a cell or off campus phone to report the fire and provide any information such as:

- 21.1.2.1 Building Name
- 21.1.2.2 Room Number

- 21.1.2.3 Type of Fire
- 21.1.2.4 Any injuries
- 21.1.2.5 Any other information requested by the emergency operator

21.1.3 If you are trained in the proper use of portable fire extinguishers and are not in immediate danger you may attempt to extinguish the fire (see Fire Extinguishers)

22.0 Fire Suppression

22.1 TAMIU uses various types of fire suppression equipment including portable fire extinguishers, water sprinklers, special gas extinguishing systems, cooking hood systems, and fire hose/standpipe systems. The following sections discuss each type of fire suppression equipment.

22.2 Sprinkler Systems

22.2.1 The purpose of a water sprinkler system is to contain and to minimize the spread of a fire, but is often successful in extinguishing fires. Sprinkler heads are normally activated by heat. Generally, if one is activated not all of the sprinklers in a building will discharge. Only in specialized sprinkler systems are they connected to smoke detectors or manual pull stations.

22.3 To ensure that sprinklers are effective in the event of a fire:

22.3.1 Maintaining a minimum of 18 inches of clearance below the sprinkler head is required to any equipment or stored items.

22.3.2 Do not hang drapes, curtains, tarps, etc that will interfere with the spray pattern of the sprinkler.

22.3.3 Never attach or hang anything from sprinkler piping or sprinkler heads

22.3.4 Do not paint or damage sprinkler heads in any manner.

22.4 Fire Extinguishing Systems

22.4.1 Special work areas such as computer server rooms or bulk chemical storage rooms may contain specialized gaseous fire extinguishing systems such as carbon dioxide (CO₂), FE 13, FM 200, or Halon 1301 in lieu of water based fire suppression systems. These systems work by displacing the oxygen in the room to a level that will no longer support a fire. To ensure that the system operates as designed, the area or room(s) protected must have its structural integrity preserved in order to maintain the required concentration level of the gas. There should be no penetrations through walls, ceilings, or floors and doors should be kept in the closed position.

22.4.2 Once a system is activated, the low level of oxygen is also dangerous to humans. Caution should be used when working in areas where these oxygen-depriving extinguishing agents are used. Manually operated systems, such as a pull-station or push button, should have signs posted indicating it will activate the agent. ***Do not*** enter a room that has discharged an oxygen-depriving agent until it has been ventilated and appropriate tests of the atmosphere have verified it is safe to enter.

22.5 Fire Hoses and Standpipe Systems

22.5.1 A standpipe system is an arrangement of piping, valves, hose connections and allied equipment installed in a building or structure for the purpose of manually extinguishing a fire. Fire hose cabinets are located in several buildings near or in the exit stairwells and in corridors. TAMIU holds the stance that employees should only attempt to extinguish a fire with a portable fire extinguisher. Local fire department responders will use the standpipe system in the event of a fire in a building. Access to these systems should be maintained at all times and should not be blocked by any equipment, chairs, desks, etc.

23.0 Liquefied Petroleum Gas (LPG)

23.1 The Texas Railroad Commission regulates the sale and use of LPG, including butane and propane. In addition, the Liquefied Petroleum Gas Code (NFPA 58) provides regulations on the use of LPG as well. These regulations govern several types of LPG-powered equipment and procedures including the following:

23.1.1 Forklifts

23.1.2 Floor buffers

23.1.3 Cooking and heating equipment

23.1.4 Laboratory equipment

23.2 Exhaust fumes may contain carbon monoxide which can present a health hazard. Exhaust can also create smoke which may activate a smoke detector. Take special precautions to ensure adequate ventilation when using these machines indoors.

23.3 Because LPG is extremely flammable, it is a potential fire hazard. Do not store LPG near heat, flame, or other ignition sources. In addition, do not leave portable LPG containers larger than 16 oz. in a building overnight. Instead, place portable LPG containers and LPG equipment outside in a storage area that is at least 25 feet away from other buildings, combustible materials, roadways, railroads, pipelines, utility lines, and the property line. This storage area should prevent unauthorized entry and have a portable fire extinguisher within 25 feet.

23.4 When using portable LPG containers the requirements listed below shall be followed:

- 23.4.1 Inspect containers for excessive denting, bulging, gouging, and corrosion and check hoses for cracks and deterioration; containers displaying any of these signs shall be removed from service
- 23.4.2 Label all containers as Flammable and as LP-Gas, Propane, or Butane
- 23.4.3 Cylinders shall be located to minimize exposure to excessive heat, and physical damage
- 23.4.4 Cylinders shall be stored away from exits, stairways, or areas normally used or intended for the use of egress for occupants
- 23.4.5 The maximum allowable quantity of LPG stored in a building shall not exceed 2 pounds
- 23.4.6 Quantities in excess of this amount shall be stored outside in a lockable ventilated enclosure of metal exterior construction; protection against vehicle impact shall be provided

23.5 LPG powered Industrial Trucks

- 23.5.1 Use of LPG powered industrial trucks shall follow the guideline for containers in the previous section, in addition to the following:
 - 23.5.1.1 LPG cylinders shall be refueled outdoors
 - 23.5.1.2 The number of cylinders on an industrial truck shall not exceed 2
 - 23.5.1.3 The size of a cylinder on an individual truck shall not exceed 45 pounds
 - 23.5.1.4 Cylinder pressure relief valve discharge shall be directed upward within 45 degrees of vertical and shall not impinge on the cylinder, exhaust system, or any other part of the truck
 - 23.5.1.5 The discharge opening shall be provided with a protective cover
 - 23.5.1.6 Trucks shall not be parked or left unattended without the cylinder shutoff valve being closed
 - 23.5.1.7 Do not park truck near areas of excessive heat or near sources of ignition

24.0 Open Burning

- 24.1 TAMIU must comply with all Texas Commission on Environmental Quality (TCEQ) guidelines for any open burns. In order to be able to conduct such a burn, several criteria must be met prior to EHS issuing an authorization to burn. These general guidelines include:
 - 24.1.1 Only natural occurring materials may be burned
 - 24.1.2 Only materials from on the site may be burned (no materials may be brought in from other locations)

24.1.3 A responsible person must be present during the entire burn and be equipped with adequate fire fighting agents, and be able to quickly communicate with emergency response personnel.

24.2 For additional information or to request an authorization to burn please contact EHS.

25.0 Pyrotechnics/Open Flames

25.1 The use of pyrotechnics or open flames on the TAMU Campus is regulated and requires a permit issued by EHS prior to any performance or use. The use of consumer fireworks on campus is prohibited.

25.2 For further information on the use of pyrotechnics or open flames or to obtain an application, refer to SAP [24.01.99.L1.05: Use of Pyrotechnics or Flame](#)

Effects 26.0 Smoking

26.1 Smoking is prohibited in all university buildings, vehicles, and in all University owned and leased housing (apartments, residence halls), and all indoor air space of University owned athletic facilities and outdoor public seating areas in athletic arenas. Where smoking is allowed, it is important to fully extinguish any smoking material or dispose in an appropriate disposal container.

27.0 Space Heaters

27.1 Some general guidelines to remember when using space heaters are:

27.1.1 Always use appliances that are UL or FM labeled.

27.1.2 Space heaters must never be left on unattended, even if you are just going to step out for a moment.

27.1.3 Space heater must be equipped with an automatic shut off feature.

27.1.4 Space heaters should be unplugged when not in use.

27.1.5 A minimum of 36" should be maintained from any combustible materials

27.1.6 Adequate space should be provided around space heaters to allow for air circulation.

27.1.7 Space heater should be plugged directly into wall receptacles

27.1.8 Frequent inspections of electrical cords for damage and to ensure a tight connection of the cord into the receptacle

27.1.9 If heater begins to spark or produce an electrical smell, turn power off immediately and discontinue using the appliance.

END OF SECTION

IX. EMERGENCY MANAGEMENT

1.0 Purpose

1.1 Texas A&M International University is subject to emergencies or disasters resulting from human-induced incidents or natural phenomena. As such, Texas A&M International University employs an “all hazards” approach as the standard for emergency management.

2.1 Phases of Emergency Management

2.2 Mitigation

2.2.1 Mitigation activities are those which eliminate or reduce the probability of a disaster occurring. Also included are those long-term activities, which lessen the undesirable effects of unavoidable hazards. Examples include fire suppressions systems in campus buildings, testing of natural gas lines and construction of detention ponds to control storm water.

2.3 Preparedness

2.3.1 Preparedness activities serve to develop the response capabilities needed in the event an emergency should arise. Planning and training are among the activities conducted under this phase.

2.4 Response

2.4.1 Response is the actual provision of emergency services during a crisis. These activities help reduce casualties and damage, and speed recovery. Response activities include warning, fire, evacuation, rescue, and other similar operations.

2.5 Recovery/Business Continuity

2.5.1 Recovery/Business Continuity is both a short-term and long-term process. Short-term operations seek to restore, or maintain vital services to the University and provide the basic needs of employees, students, and visitors. Long-term recovery focuses on restoring the University to its normal pre-disaster, or an improved, state of affairs. The recovery/business continuity phase is also an opportune time to institute future mitigation measures, particularly those related to the recent emergency.

3.1 Roles and Responsibilities

3.2 Individual

3.2.1 Given that emergencies cannot always be avoided, our common first line of defense is our own initial actions (i.e., those things that we do before emergency responders arrive). These actions are:

3.2.1.1 Maintain situational awareness

3.2.1.1.1 At its core, situational awareness involves being aware of where you are and what is happening around you to understand how information, events, and your own actions will impact your safety and your ability to protect yourself, both now and in the near future.

3.2.1.2 Take actions to protect yourself

3.2.1.2.1 Based upon your assessment of the situation, use your best judgment to protect yourself and, if possible, others (e.g., evacuate or shelter-in-place).

3.2.1.3 Summon assistance

3.2.1.3.1 Call for help.

3.2.1.3.2 See Section 4, Summoning Emergency Services, below.

3.2.1.4 Warn others

3.2.1.4.1 Once you are safely away from the danger, warn others of the hazard.

3.2.2 Detailed procedures can be found on Uconnect:

3.2.2.1 <https://lumptl.tamtu.edu/cp/home/displaylogin>

3.3 Colleges, Divisions, and Departments

3.3.1 Every college, division, and department has a responsibility to ensure a safe environment for its employees and to maintain operations.

- 3.3.2 Each college, division and/or department is encouraged to have a business continuity plan.
- 3.3.3 Contact the Office of Environmental Health and Safety for further assistance regarding emergency management.

3.4 University

- 3.4.1 Texas A&M International University, through the Office of Environmental Health and University Police Department, is responsible for maintaining the emergency management program ranging from:
 - 3.4.1.1 Maintaining the broad-based Texas A&M International University Emergency Management Plan, and associated plans;
 - 3.4.1.2 Maintaining the emergency exercise and training program;
 - 3.4.1.3 Maintaining public awareness on emergencies; and
 - 3.4.1.4 Coordinating University efforts with local and regional partners.

4.0 Summoning Emergency Services

- 4.1 To summon emergency services, call 9-911 from a campus phone or 911 from a non-campus phone (e.g., cell phone). You can also contact UPD dispatch at 326-2911. Remember to remain calm, notify others, and respond to the emergency as appropriate. Do not attempt to handle any emergency situation in which you do not have training (e.g., firefighting, first aid, spill response, etc.).
 - 4.1.1 Relay the following information to the emergency dispatcher:
 - 4.1.1.1 Your location – building name and area
 - 4.1.1.2 Nature of emergency
 - 4.1.1.3 If there are any injuries
 - 4.1.1.4 Your name and the phone number you are calling from
 - 4.1.2 Remember to always:
 - 4.1.2.1 Answer the emergency dispatcher's questions
 - 4.1.2.2 Follow all directions given

4.1.2.3 Do not hang up until told

4.1.3 Campus Emergency Telephones

4.1.3.1 Texas A&M International maintains more than 10 “blue light” emergency telephones on campus. Use these for local calls and/or for calling 911 to summon emergency services.

4.1.4 Other Emergency Telephone Numbers

4.1.4.1 University Police Dispatch – (956) 326-2911

4.1.4.2 University Student Health Services – (956) 326-2237

4.1.4.3 Physical Plant – (956) 326-2325

4.1.4.4 Environmental Health & Safety – (956) 326-2756

5.0 Training Resources

5.1 As part of an educational institution, it is important to provide training and educational opportunities for all those interested in learning more about emergency preparedness. For additional information about specific trainings that can be provided to students, faculty, and staff, please contact the Office of EH&S.

6.0 Warning Systems

6.1 Texas A&M International University has many warning systems on campus. Each warning system is just one “tool” in the campus “warning toolbox”. Any one warning system can be used, as well as any system can be used in conjunction with others. In combination, Texas A&M International University is able to provide timely warnings to the campus community for imminent threats to safety and security.

6.1.1 **Dustyalrt** – Dustyalrt is Texas A&M International University’s emergency warning system comprised, but not limited to, SMS (text message), email and on-campus cable television.

6.1.2 The following are brief descriptions of the types of warning systems utilized by the University:

6.1.2.1 **Building Fire Alarm Systems** – These warning systems are ideal to provide immediate warnings to individuals within a given building.

- 6.1.2.2 **Bull Horns (Megaphones)** – Megaphones are often utilized by fire departments and law enforcement to project a warning message quickly to people within a defined area.
- 6.1.2.3 **Weather Radios** – Weather radios provide timely warnings to a broad populous for weather (or potential) emergencies activated by the National Weather Service.
- 6.1.2.4 **Email / Text Messaging** – Members of the Texas A&M International campus community may receive email and/or text message warnings through voluntary participation in this system.
- 6.1.2.5 **Television / Radio** – Television and radio broadcasts are ideal for broad distribution of an emergency message to the masses. The message distribution can be accomplished by working with the media or automated text crawlers for television.
- 6.1.2.6 **Emergency Notification System** – Texas A&M International University utilizes a mass notification system that utilizes loud speakers, digital signage, e-mail crawl, and office speakers to send emergency messages.
- 6.1.2.7 **TAMIU Emergency Website** – Emergency messages will be posted on the TAMIU emergency website containing more detailed emergency information that otherwise can not be distributed by other warning systems.
- 6.1.2.8 **Word of Mouth** – The most effective warning system is by word of mouth, whether it is from university officials or people passing on the emergency warning to others.

END OF SECTION

PERSONAL PROTECTIVE EQUIPMENT

1.0 Personal Protective Equipment Defined

- 1.1 Personal Protective Equipment (PPE) includes all clothing and work accessories designed to protect employees from workplace hazards. Protective equipment should not replace engineering, administrative, or procedural controls for safety — it should be used in conjunction with these controls. Employees must wear protective equipment as required and when instructed by a supervisor.



IMPORTANT: Personal protective equipment that is used to prevent exposure or contamination should always be removed before coming in contact with other individuals or going in or near elevators, break rooms, classrooms, bathrooms, etc. Do not launder personal protective equipment at home.

2.0 Arm and Hand Protection

- 2.1 Arms and hands are vulnerable to cuts, abrasions, temperature extremes, burns, bruises, electrical shock, chemical spills, and amputation. The following forms of hand protection are available for employees:

- 2.1.1 Disposable exam gloves
- 2.1.2 Rubber gloves
- 2.1.3 Nitrile gloves
- 2.1.4 Neoprene gloves
- 2.1.5 Leather gloves
- 2.1.6 Non-asbestos heat-resistant gloves
- 2.1.7 Metal-mesh gloves for meat cutters
- 2.1.8 Cotton gloves
- 2.1.9 Kevlar or Dynema gloves for cut resistance



- 2.2 Always wear the appropriate hand and arm protection. For arm protection, wear a long-sleeved shirt, a laboratory coat, chemical-resistant sleeves, or gauntlet-length gloves.
- 2.3 Follow these guidelines to ensure arm and hand safety:
- 2.3.1 Inspect and test new gloves for defects.
 - 2.3.2 Always wash your hands before and after using gloves. Wash chemical-protective gloves with soap and water before removing them.
 - 2.3.3 Do not wear loose fitting gloves near moving machinery; the gloves may become caught.
 - 2.3.4 Do not wear gloves with metal parts near electrical equipment.

IMPORTANT: *Gloves are easily contaminated. Avoid touching surfaces such as telephones, door knobs, etc. when wearing gloves.*

3.0 Body Protection

3.1 Hazards that threaten the torso tend to threaten the entire body. A variety of protective clothing, including laboratory coats, long pants, rubber aprons, coveralls, and disposable body suits are available for specific work conditions.

3.1.1 Rubber, neoprene, and plastic clothing protect employees from most acids and chemical splashes.

3.1.2 Laboratory coats and coveralls protect employees and everyday clothing from contamination.

3.1.3 Welding aprons provide protection from sparks.



3.2 Do not launder contaminated chemically, biologically, or radiologically protective clothing at home or in any facilities outside of the university.

4.0 Ear and Hearing Protection

4.1 If you work in a high noise area, wear hearing protection. Most hearing protection devices have an assigned rating that indicates the amount of protection provided. Depending on your level of exposure, you may choose from the following devices:

4.1.1 Disposable earplugs

4.1.2 Reusable earplugs

4.1.3 Headband plugs

4.1.4 Sealed earmuffs



4.2 Earplugs may be better in hot, humid, or confined work areas. They may also be better for employees who wear other PPE, such as safety glasses or hats. Earmuffs, on the other hand, may be better for employees who move in and out of noisy areas, because the muffs are easier to remove. Before resorting to hearing protection, attempt to control noise levels through engineering or operational changes.

4.3 To avoid contamination, follow these guidelines when using earplugs:

4.3.1 Wash your hands before inserting earplugs.

4.3.2 Replace disposable earplugs after each use.

4.3.3 Clean reusable earplugs after each use.

- 4.4 Refer to the Hearing Conservation Program in the General Safety chapter or contact the Environmental Health & Safety Department for more information.

5.0 Eye and Face Protection

- 5.1 Employees must wear protection if hazards exist that could cause eye or face injury. Eye and face protection should be used in conjunction with equipment guards, engineering controls, and safe practices.

NOTE: Safety glasses are required in laboratories. Chemical goggles should be worn when handling chemical materials.

- 5.2 Always wear adequate eye and face protection when performing tasks such as grinding, buffing, welding, chipping, cutting, or pouring chemicals. Safety glasses with side shields provide protection against impact, but chemical safety goggles provide protection against impact, splashes, and hazardous atmospheres.

- 5.3 Follow the below information regarding eye protection:

5.3.1 If you wear prescription glasses, wear goggles or other safety protection over the glasses.

5.3.2 Safety glasses with side-shields provide primary protection to eyes and are four times as resistant as prescription glasses to impact injuries.

5.3.3 Goggles protect against impacts, sparks, dust, and irritating mist. Wear chemical splash goggles, not just safety glasses, when working with chemicals.

5.3.4 A welding helmet protects from flash burn due to welding, soldering, or brazing, but does not provide primary eye protection; safety glasses or goggles should be worn with the helmet.

5.3.5 A face shield is designed to protect the face from some splashes or projectiles, but does not eliminate exposure to vapors. A face shield should be worn with goggles or safety glasses.



To reduce eyestrain from glare and outdoor sun exposure use safety glasses with UV protection to minimize the ultraviolet light exposure

6.0 Foot Protection

- 6.1 To protect feet and legs from falling objects, moving machinery, sharp objects, hot materials, chemicals, or slippery surfaces, employees should wear closed-toed shoes, boots, foot-guards, leggings, or safety shoes as appropriate. Safety shoes are designed to protect people from the most common causes of foot injuries — impact, compression, and puncture. Special foot protection is



also available for protection against static electricity, sparks, live electricity, corrosive materials, and slipping.

NOTE: Foot protection is particularly important in laboratory, agricultural, construction and custodial work.

IMPORTANT: Do not wear sandals, crocs, or open-toed shoes in laboratories, shops, food prep, food serving, or other potentially hazardous areas.

7.0 Head Protection

7.1 Accidents that cause head injuries are difficult to anticipate or control. If hazards exist that could cause head injury, employees should try to eliminate the hazards, but they should also wear head protection.



7.2 Safety hats protect the head from impact, penetration, and electrical shock. Head protection is necessary if you work where there is a risk of injury from moving, falling, or flying objects or if you work near high-voltage equipment.

7.3 Hard hats should be water resistant, flame resistant, and adjustable. Wear one of the following hard hats as appropriate for your work situation:

7.3.1 Class G - General service, limited voltage (2,200 Volts) protection

7.3.2 Class E - Utility service, high-voltage (20,000 Volts) protection

7.3.3 Class C - Special service, no voltage protection

7.4 Follow these guidelines for head safety:

7.4.1 Check the shell and suspension of your headwear for damage before each use. Look for cracks, dents, gouges, chalky appearance, and torn or broken suspension threads. Discard damaged hats or replace broken parts with replacements from the original manufacturer.

7.4.2 Discard any hat that has been struck or dropped from a great height, even if there is no apparent damage.

7.4.3 Do not wear a hard hat backwards, unless this is necessary to accommodate other protective equipment (e.g., welders face shield).

7.4.4 Do not paint the plastic shell of a hard hat or alter it in any way.

8.0 Respiratory Protection Program

8.1 TAMIU uses engineering, administrative, and procedural controls to protect people from dangerous atmospheres, including harmful mists, smoke, vapors, and oxygen-deficient atmospheres. When these controls cannot provide adequate protection against harmful atmospheres,



respiratory protection is necessary.

- 8.2 The Environmental Health & Safety Department can provide training and fit testing for personnel who need respiratory protection.

9.0 Usage Requirements

- 9.1 People who use respiratory protection must be physically capable of using and wearing the equipment. In some cases, a physician must determine if an employee is healthy enough to use a respirator. In addition, all people required to wear respirators must be formally trained and instructed in proper equipment usage. This training should include instruction on common respiratory hazards and symptoms of exposure.
- 9.2 Before wearing a respirator employees must be fit tested by EHS to ensure their respirator protection equipment is the proper size and fits appropriately. Fit testing must be done annually or more frequently based on substantial weight gain/loss or facial surgery.

NOTE: Only use respirators that are approved by NIOSH

10.0 Selecting a Respirator

- 10.1 EHSD will help departments to select the respirator. When selecting a respirator, consider the following factors:
 - 10.1.1 Type of hazards
 - 10.1.2 Identity and concentration of the contaminant
 - 10.1.3 Time constraints
 - 10.1.4 Activity of the person wearing the respirator
 - 10.1.5 Degree of protection provided by each type of respirator

IMPORTANT: Respirators are available in different sizes. Always fit test a respirator to select the correct size.

11.0 Using Respirators Safely

- 11.1 Your respirator is necessary to prevent the inhalation of particulates, gases, vapors, aerosols, or other contaminants. Be sure you have notified EHS of all

hazardous chemicals or materials you will be working with to ensure you have been provided the best possible respiratory protection.

11.2 It is important to remember the following:

- 11.2.1 Only use the respirator you were approved to wear and that has been properly fit tested.
- 11.2.2 You must be familiar with the respirator, its use and limitations, and how to properly maintain and care for your respirator.
- 11.2.3 You may not have facial hair that interferes with the seal of a tight fitting respirator. If you were fit tested without facial hair or with a minimal amount of facial hair, you must not wear your respirator with additional hair growth.
- 11.2.4 You should contact EHS to be fit tested again if you have facial or dental surgery, significant weight gain or loss, facial scarring, or anything else that might affect the fit and seal of your respirator.
- 11.2.5 You should be fit tested annually.

11.3 Safety Tips:

- 11.3.1 Inspect respirator before and after each use to ensure that all parts are present or attached and are functioning properly.
- 11.3.2 Rubber and plastic parts should be checked for signs of wear and tear (cracking, stiffness, etc.). If you identify any worn or weak parts, do not use the respirator.
- 11.3.3 Perform a positive pressure and negative pressure seal check every time you put on the respirator:

NOTE: Positive pressure check: Cover the exhalation valve of the respirator with the palm of your hand. Exhale gently for about 10 seconds to build up a slight pressure. If air leaks out, the respirator is not sealing properly and should be repositioned before entering the hazardous area.

NOTE: Negative pressure check: Cover the filter or cartridge openings of the respirator with the palms of your hands. Inhale gently and hold your breath for about 10 seconds. You should notice a slight suction. If the face piece does not collapse inward or you feel an air leak, the respirator is not sealing properly and should be repositioned before entering the hazardous area.

11.4 Leave the respiratory protection area if any of the following occur:

- 11.4.1 If your respirator is damaged.
- 11.4.2 If your breathing becomes difficult.
- 11.4.3 If you become dizzy.
- 11.4.4 If you detect a respirator failure (smell something you did not notice before, eyes begin to water, etc.).
- 11.4.5 If you feel your seal has been broken (air getting in or out around your face piece).

DO NOT REMOVE OR REPOSITION YOUR MASK UNTIL YOU HAVE LEFT THE AREA.

11.5 Storage, Cleaning, and Care:

- 11.5.1 Store respirator in a clean, cool area (away from dust, sunlight, extreme temperatures, moisture, and chemicals).
- 11.5.2 Do not hang respirator by headband.
- 11.5.3 The respirator should be cleaned regularly with respirator wipes or a detergent solution. All parts should air dry or be wiped dry with a lint free cloth.
- 11.5.4 Clean and disinfect the respirator after each use if shared by more than one person (NOTE: respirators may be shared only by individuals who have been properly trained and fit tested for that respirator).

END OF SECTION

X. LABORATORY SAFETY

1.0 General Safety Guidelines

- 1.1 Laboratory Safety incorporates safety principles from a variety of areas, including fire and life safety, chemical safety, biological safety and radiation safety. The hazards encountered in a laboratory touch every field in safety and may be similar, although potentially greater in quantity or severity, to hazards encountered in the average home or work place.
- 1.2 Laboratory Safety is overseen by Environmental Health & Safety, the Department of Biology and Chemistry, and the Office of Graduate Studies and Research. This groups work to ensure that safe practices are utilized and that state, national, and international safety standards or requirements are followed. This is accomplished through conducting laboratory inspections, testing of chemical fume hoods and other safety equipment, and providing general laboratory safety training.
- 1.3 Specific information on safe lab practices can be found in the TAMIU Laboratory Safety Manual. This document contains information on the different hazards that may be found in laboratories - including chemical hazards, physical hazards, biological hazards and radiological hazards - and how to minimize the risks associated with those hazards. The TAMIU Laboratory Safety Manual also provides information on training requirements for laboratory personnel, how to protect oneself when working in a laboratory, and how to plan for an emergency situation in the laboratory.
- 1.4 For specific questions relating to Laboratory or Chemical Safety, contact the Office of EH&S or review the Texas A&M International University Laboratory Safety Manual.

END OF SECTION

XI. BIOLOGICAL SAFETY

The Biological Safety Program is managed by the Office of Environmental Health and Safety and the TAMIU Biosafety Committee. Guidance documents, requirements, and training sessions are offered and should be consulted when employees work with or have the potential to come in contact with biohazardous materials.

1. Biohazardous materials are potentially hazardous biological agents and include the following:
 - 1.1. Etiologic agents which may cause disease in humans, animals or plants (including bacterial, fungal, parasitic, rickettsial, viral, and prion disease agents)
 - 1.2. Human body fluids or tissues (e.g. bloodborne pathogens) including human cell culture (primary or continuous)
 - 1.3. Agents and molecules involved with recombinant DNA biotechnology and genetic manipulation (including recombinant / transgenic agents including plants, animals, as well as pathogenic and non-pathogenic microorganism (eukaryotic and prokaryotic)
 - 1.4. Animals infected with zoonoses
 - 1.5. Items contaminated with etiologic agents or human body fluids or tissues.
2. **Possession and use of biohazardous materials for research requires prior approval by Texas A&M International Institutional Biosafety Committee (IBC).**

END OF SECTION

CHAPTER 13

CHEMICAL SAFETY

SECTION 1: OVERVIEW

Almost everyone works with or around chemicals and chemical products every day. Chemical safety is inherently linked to other safety issues including engineering controls, laboratory procedures, personal protective equipment, electrical safety, fire safety, and hazardous waste disposal.

Many chemicals have properties that make them hazardous: they can represent physical hazards (fire, explosion) and/or health hazards (toxicity, chemical burns, and dangerous fumes). However, there are many ways to work with chemicals which can both reduce the probability of an accident and minimize the consequences should an accident occur.



Risk minimization depends on safe practices, appropriate engineering controls for chemical containment, the proper use of personal protective equipment, the use of the minimum quantity of material necessary, and/or substitution of less hazardous chemicals. Before beginning an operation, one should ask "What would happen if . . .?" The answer to this question requires an understanding of the hazards associated with the chemicals, equipment and procedures involved. The hazardous properties of the material and its intended use will dictate the precautions to be taken.

It is important to distinguish the difference between *hazard* and *risk*. The two terms are sometimes used as synonyms. In fact, the term "hazard" is a much more complex concept because it includes conditions of use. The hazard presented by a chemical has two components: (1) its inherent capacity to do harm by virtue of its toxicity, flammability, explosiveness, corrosiveness, etc.; and (2) the ease with which the chemical can come into contact with a person or other object of concern. The two components together determine "risk" – the likelihood or probability that a harmful consequence will occur. Thus, an extremely toxic chemical such as strychnine cannot cause poisoning if it is in a sealed container and does not contact the handler. In contrast, a chemical that is not highly toxic can be lethal if a large amount is ingested.

It should be noted that not all chemicals are considered *hazardous*. Examples of nonhazardous chemicals include pH neutral buffers, sugars, starches, agar, and naturally occurring amino acids. This chapter will focus on hazardous chemicals.

SECTION 2: HAZARD COMMUNICATION PROGRAM

TAMIU has a written program (the [TAMIU Hazard Communication Program](#)) for hazardous chemicals that complies with the Texas Hazard Communication Act (THCA). This program is available from Environmental Health & Safety. It requires the following:

- a. Employee training (including recognition of signs of exposure)
 - i. General – Provided by EHS
 - ii. Work Area Specific – Provided by individual’s supervisor (PI, laboratory manager, etc.)
- b. Employee supervision
- c. Labeling requirements
 - i. Primary container labels – Must have the original manufacturer’s label, which includes the chemical name, hazards, and manufacturer’s information.
 - ii. Secondary container labels – Must identify the chemical as it is on the Material Safety Data Sheet (MSDS) and the hazards.

***Exemptions** – Research laboratories are exempt from the secondary container labeling requirements under THCA. However, TAMIU requires that all containers be labeled so as to somehow identify the contents.*
- d. Availability of SDSs (formally MSDS)
- e. Provision of personal protective equipment (PPE)
- f. Work area chemical inventories
- g. Recordkeeping requirements
- h. Emergency response procedures

Refer to the [TAMIU Hazard Communication Program](#) and other sections in this manual for more information on these topics.

SECTION 3: HAZARD IDENTIFICATION

An integral part of hazard communication is hazard identification. Everyone who works with hazardous chemicals should know how to read and interpret hazard information. Signs, labels, placards, and symbols alert employees to the known hazards in a particular location.

The National Fire Protection Association (NFPA) diamond in the illustration below is one method of identifying chemical hazards. NFPA uses a scale of 0 – 4 to rate each hazard, with 0 indicating “no hazard” and 4 indicating the most extreme hazard. The following is a detailed explanation of the NFPA hazard classification codes:

a. Health (Blue):

- 4 - Can cause death or major injury despite medical treatment
- 3 - Can cause serious injury despite medical treatment
- 2 - Can cause injury. Requires prompt medical treatment
- 1 - Can cause irritation if not treated
- 0 - No hazard

b. Flammability (Red):

- 4 - Very flammable gases or liquids
- 3 - Can ignite at normal temperatures
- 2 - Ignites with moderate heat
- 1 - Ignites with considerable preheating
- 0 - Will not burn

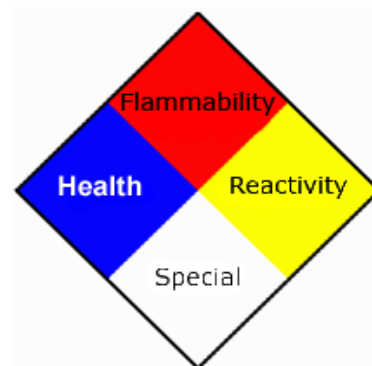

c. Reactivity (Yellow):

- 4 - Readily detonates or explodes
- 3 - May detonate or explode with strong initiating force or heat under confinement
- 2 - Normally unstable, but will not detonate
- 1 - Normally stable. Unstable at high temperature and pressure.
- 0 - Normally stable and not reactive with water.

d. Specific Hazard (White):

- Oxidizer - OX
- Acid - ACID
- Alkali - ALK
- Corrosive - COR
- Use No Water - Ψ
- Radioactive - (see image at right)



Many chemicals fall under more than one hazard class. Extra care should be taken when handling or storing chemicals with multiple hazards.

Other labeling systems may also be used. For instance, the Department of Transportation (DOT) has a labeling system for the shipment of hazardous materials. Examples of DOT placards are shown within the text of this chapter.

SECTION 4: CHEMICAL SAFETY GUIDELINES

Always follow these guidelines when working with chemicals:

- a. Assume that any unfamiliar chemical is hazardous and treat it as such.
- b. Know all the hazards of the chemicals with which you work. For example, perchloric acid is a corrosive, an oxidizer, and a reactive. Benzene is an irritant that is also flammable, toxic, and carcinogenic.
- c. Never underestimate the potential hazard of any chemical or combination of chemicals. Consider any mixture or reaction product to be at least as hazardous as – if not *more* hazardous than – its most hazardous component.
- d. Never use any substance that is not properly labeled. It may not be what you think it is!
- e. Date all chemicals when they are received and again when they are opened.
- f. Follow all chemical safety instructions, such as those listed in Material Safety Data Sheets or on chemical container labels, precisely.
- g. Minimize your exposure to any chemical, regardless of its hazard rating, and avoid repeated exposure.
- h. Use personal protective equipment (PPE), as appropriate for that chemical.
- i. Use the buddy system when working with hazardous chemicals. Don't work in the laboratory alone.



SECTION 5: MATERIAL SAFETY DATA SHEETS

Before using any chemical, read the appropriate Material Safety Data Sheet (MSDS). An MSDS is a document that details information about chemicals and along with the container label is a good source of information for chemical safety. It provides the following information:

- a. Identity of the chemical
- b. The manufacturer's name and address
- c. Hazardous ingredients
- d. Exposure limits
 - i. Permissible Exposure Limit (PEL) or Recommended Exposure Limit (REL) – This is the amount of a chemical that a person can be exposed to, averaged over an eight hour period, before it causes him/her harm.
 - ii. Short Term Exposure Limit (STEL) – This is the amount of a chemical that a person can be exposed to, averaged over a 15 minute period, before it causes him/her harm.
 - iii. Immediately Dangerous to Life and Health (IDLH) – This is the amount of chemical that immediately puts a person a risk of serious injury or death. If this level is reach or exceeded, the area should be evacuated immediately!

- e. Physical characteristics, such as:
 - i. Boiling point
 - ii. Vapor pressure
- f. Chemical hazards, including the following:
 - i. Flammability
 - ii. Explosiveness
 - iii. Reactivity
- g. Health hazards, including chemicals that are:
 - i. Toxins (both acute and long-term)
 - 1. Carcinogens
 - 2. Reproductive Toxins
 - 3. Teratogens
 - 4. Mutagens
 - 5. Neurotoxins
 - ii. Irritants
- h. Routes of Entry
- i. Emergency and first-aid procedures
- j. Proper leak, spill, and disposal techniques
- k. Proper storage and handling procedures
- l. Other special provisions



Each person working with chemicals should have access to the MSDS for all chemicals they use. "Access" may be:

- A current hard copy kept in a work area file or binder.
- An electronic copy.

SECTION 6: SAFE HANDLING GUIDELINES

Employees should treat all chemicals and equipment with caution and respect. When working with chemicals, remember to do the following:

- a. Wear appropriate personal protective equipment (PPE) for the chemical hazard.
- b. Remove and use only the amount of chemicals needed for the immediate job at hand.
- c. Properly seal, label, and store chemicals in appropriate containers. Keep the containers clearly marked and in a well-ventilated area.

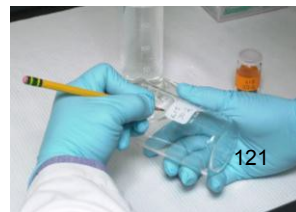

- d. Segregate and store chemicals by their hazard class.
- e. Check stored chemicals for deterioration and for damage to the containers.
- f. Learn how to dispose of chemicals safely and legally. Follow TAMIU waste disposal requirements.
- g. Clean up spills and leaks immediately.
- h. Develop a Plan of Action for how to respond in an emergency. Review this plan regularly to be familiar with it.
- i. Do not store chemicals near heat, in sunlight, or near substances which might initiate a dangerous reaction.
- j. When transporting chemicals between the work area and other areas, use secondary containment (such as a tray, rack, cart or rubber carrier) to protect against spills, leaks or container breakage. Always use a secondary container when transporting hazardous or highly odorous chemicals on an elevator.
- k. Never pour any chemicals down the sink. Use proper hazardous waste disposal procedures for all excess or unused chemicals.



SECTION 7: CHEMICAL STORAGE GUIDELINES

Proper chemical storage is as important to safety as proper chemical handling. Often, seemingly logical storage ideas, such as placing chemicals in alphabetical order, may cause incompatible chemicals to be stored together.

7.1 GENERAL STORAGE GUIDELINES

Follow these guidelines for safe chemical storage:

- a. Read chemical labels and the MSDS for specific storage instructions.
- b. Store chemicals in a well-ventilated area; however, *do not* store chemicals in a fume hood.
- c. Date all chemicals when they are received and again when they are opened.
- d. Maintain an inventory of all chemicals in storage. A copy of the inventory should be maintained at a location outside of the laboratory.
- e. Return chemical containers to their proper storage location after use.
- f. Store glass chemical containers so that they are unlikely to be broken. Glass containers should never be stored directly on the floor.
- g. Store all hazardous liquid chemicals below eye level of the shortest person working in the laboratory.
- h. Never store hazardous chemicals in a public area or corridor. Hazardous chemicals must be kept in a secured area.

7.2 SEPARATING AND STORING HAZARDOUS CHEMICALS

In addition to the guidelines above, there are storage requirements for separating hazardous chemicals. Follow these guidelines to ensure that hazardous chemicals are stored safely:

- a. Group chemicals according to their hazard category (i.e., corrosives, flammables, toxins, etc.), not alphabetically, and separated by some sort of physical barrier. An alphabetical storage system may place incompatible chemicals next to each other.
- b. Separate acids from bases and inorganic acids or bases from organic acids or bases. Store these chemicals near floor level.
- c. Isolate perchloric acid from all other chemicals and from organic materials. Do not store perchloric acid on a wooden shelf or spill paper.
- d. Separate highly toxic chemicals and carcinogens from all other chemicals. This storage location should have a warning label and should be locked.
- e. Time-sensitive chemicals, such as those that form peroxides, should not be kept longer than twelve months from purchase or six months after opening. If stratification of liquids, precipitate formation, and/or change in color or texture is noted, contact EHS immediately.
- f. Picric acid *must* be stored under a layer of liquid, as picric crystals are highly explosive. If picric acid dries out (forming yellow crystals), do not touch the container! Contact EHS immediately!
- g. If flammables need to be chilled, store them in a laboratory-safe refrigerator, not in a standard (household style) refrigerator.
- h. Chemicals may be stored in the cabinets underneath a chemical fume hood provided the cabinetry is designed for that use.
 - i. Cabinetry designed for flammable storage vents into the fume hood exhaust duct.
 - ii. Cabinetry designed for corrosives storage vents directly into the fume hood. Flammable chemicals should *never* be stored in this type of cabinets!
 - iii. Some cabinetry is only designed for general storage or with a drying rack. These cabinets are not meant to be used for hazardous chemical storage.
- i. Flammables should be stored in a well ventilated area and large quantities in a flammable storage cabinet. Contact EHS for more information on allowable storage of flammable liquids per NFPA Code.

The following table provides examples of incompatible chemicals:

CHEMICAL	INCOMPATIBLE WITH . . .
----------	-------------------------

Acetic acid	Chromic acid, nitric acid, hydroxyl compounds, ethylene glycol, perchloric acid, peroxides, permanganates
Acetylene	Chlorine, bromine, copper, fluorine, silver, mercury
Acetone	Concentrated nitric and sulfuric acid mixtures
Alkali metals	Water, carbon tetrachloride or other chlorinated hydrocarbons, carbon dioxide, halogens
Ammonia	Mercury, chlorine, calcium hypochlorite, iodine, bromine, hydrofluoric acid
Chlorates	Ammonium salts, acids, powdered metals, sulfur, finely divided organic or combustible materials
Chlorine	Ammonia, acetylene, butadiene, butane, methane, propane (or other petroleum gases), hydrogen, sodium carbide, benzene, finely divided metals, turpentine
Cyanide	Acids
Fluorine	Most other chemicals
Nitrates	Sulfuric acid
Oxygen	Oils, grease, hydrogen, flammable liquids, solids, or gases
Perchloric acid	Acetic anhydride, bismuth and its alloys, alcohol, paper, wood, grease, oils,
Sodium	Carbon tetrachloride, carbon dioxide, water
Sulfides	Acids

See the [EHS website](#) for more information on segregating incompatible chemicals and other storage guidelines.

SECTION 8: HYGIENE AND CHEMICAL SAFETY

Good personal hygiene will help minimize exposure to hazardous chemicals. When working with chemicals, follow these guidelines:

- Wash hands frequently and before leaving the laboratory. Also, wash hands before eating, drinking, smoking or applying makeup.
- Wear appropriate personal protective equipment (PPE). Always wear protective gloves when handling any hazardous chemicals.
- Remove PPE before leaving the laboratory and before washing hands.
- Remove contaminated clothing immediately. Do not use the clothing again until it has been properly decontaminated.
- Follow any special precautions for the chemicals in use.
- Do not eat, drink, smoke or apply makeup around chemicals.
- Tie back long hair when working in a laboratory or around hazardous chemicals.



- h. Do not keep food, beverages, or food and beverage containers anywhere near chemicals or in laboratories where chemicals are in use.
- i. Do not use laboratory equipment, including laboratory refrigerators/freezers, to store or serve food or drinks.
- j. Do not wash food and beverage utensils in a laboratory sink.
- k. Do not sniff or taste chemicals.
- l. Do not touch door knobs, telephones, computer keyboards, etc. with contaminated gloves.

SECTION 9: TYPES OF CHEMICAL HAZARDS

9.1 CORROSIVES

Corrosive chemicals destroy or damage living tissue by direct contact. Some acids, bases, dehydrating agents, oxidizing agents, and organics are corrosives. Examples of the different types of corrosive chemicals are listed below:

- Acidic corrosives:
 - Inorganic Acids
 - Hydrochloric acid
 - Nitric Acid
 - Sulfuric acid
 - Organic Acids
 - Acetic Acid
 - Propionic acid
- Alkaline, or basic, corrosives:
 - Sodium hydroxide
 - Potassium hydroxide
- Corrosive dehydrating agents:
 - Phosphorous pentoxide
 - Calcium oxide
- Corrosive oxidizing agents:
 - Halogen gases
 - Hydrogen peroxide (concentrated)
 - Perchloric acid
- Organic corrosive:
 - Butylamine



Health Consequences

Extreme caution should be taken when handling corrosive chemicals, or severe injury may result.

- a. Concentrated acids can cause painful and sometimes severe burns.
- b. Inorganic hydroxides can cause serious damage to skin tissues because a protective protein layer does not form. Even a dilute solution such as sodium or potassium hydroxide can attack skin by reacting with the fat tissues and forming a soapy, slick film.
- c. At first, skin contact with phenol may not be painful, but the exposed area may turn white due to the severe burn. Systemic poisoning may also result from dermal exposure.
- d. Skin contact with low concentrations of hydrofluoric acid (HF) may not cause pain immediately but can still cause tissue damage if not treated properly. Higher concentrations of HF (50% or greater) can cause immediate, painful damage to tissues.

Safe Handling Guidelines for Corrosives

To ensure safe handling of corrosives, the following special handling procedures should be used:

- a. Always store corrosives properly. Segregate acids from bases and inorganics from organics. Refer to the Chemical Storage section of this chapter for more information.
- b. Always wear a laboratory coat, gloves and chemical splash goggles when working with corrosives. Wear other personal protective equipment, as appropriate.
- c. To dilute acids, carefully add the acid to the water, not the water to the acid. This will minimize any reaction.
- d. Corrosives, especially inorganic bases (e.g., sodium hydroxide), may be very slippery; handle these chemicals with care and clean any spills, leaks, splashes, or dribbles immediately.
- e. Work in a chemical fume hood when handling fuming acids or volatile irritants (e.g., ammonium hydroxide).
- f. A continuous flow eye wash station should be in every work area where corrosives are present. An emergency shower should also be within 55 feet of the area.

Corrosive Example: Perchloric Acid

Perchloric acid is a corrosive oxidizer that can be dangerously reactive. At elevated temperatures, it is a strong oxidizing agent and a strong dehydrating reagent. Perchloric acid reacts violently with organic materials. When combined with combustible material, heated perchloric acid may cause a fire or explosion. Cold perchloric acid at less than 70% concentration is not a very strong oxidizer, but its oxidizing strength increases significantly at concentrations higher than 70%. Anhydrous perchloric acid (>85%) is very unstable and can decompose spontaneously and violently.

When using perchloric acid, remember the following:

- a. Be thoroughly familiar with the special hazards associated with perchloric acid before using it.
- b. If possible, purchase 60% perchloric acid instead of a more concentrated grade.
- c. Always wear rubber gloves and chemical splash goggles while using perchloric acid. Consider also wearing a face shield and rubber apron if splashing is likely.
- d. Store perchloric acid inside secondary containment (such as a Pyrex dish) and segregated from all other chemicals and organic materials. Do not store bottles of perchloric acid in wooden cabinets or on spill paper.

IMPORTANT: Heated digestions with perchloric acid require a special fume hood with a wash-down system. A perchloric acid fume hood should also be used when handling highly concentrated (greater than 70%) perchloric acid.

9.2 FLAMMABLES

A flammable chemical is any solid, liquid, vapor, or gas that ignites easily and burns rapidly in air. Consult the appropriate MSDS before beginning work with flammables.



Flashpoint, Boiling Point, Ignition Temperature, and Class

Flammable chemicals are classified according to flashpoint, boiling point, fire point, and auto-ignition temperature.

- a. Flash Point (FP) is the lowest temperature at which a flammable liquid's vapor burns when ignited.
- b. Boiling Point (BP) is the temperature at which the vapor pressure of a liquid is equal to the atmospheric pressure under which the liquid vaporizes. Flammable liquids with low BPs generally present special fire hazards.
- c. Fire Point is the temperature at which the flammable liquid will burn.
- d. Auto-ignition Temperature is the lowest temperature at which a substance will ignite without an ignition source.

Flammable liquids are classified according to how easily they burn. The following table illustrates flammable class characteristics as defined by NFPA 45:

FLAMMABLE CLASS	FLASHPOINT (°F)	BOILING POINT (°F)	EXAMPLES
1A	<73	<100	Diethyl ether "Flammable" aerosols
1B	<73	≥100	Acetone Gasoline Toluene
1C	≥73	<100	Butyl alcohol Methyl isobutyl ketone Turpentine
2	100 - 140	---	Cyclohexane Kerosene Mineral spirits
3A	140 - 199	---	Butyl cellosolve
3B	>200	---	Cellosolve Ethylene glycol Hexylene glycol

The following table provides examples of common flammables and their flashpoint and class.

CHEMICAL	FLASHPOINT (°F)	FLAMMABLE CLASS
Acetone	0	1B
Benzene	12	1B
Butyl Acetate	>72	1C
Carbon Disulfide	-22	1B
Cyclohexane	-4	1B
Diethylene Glycol	225	3B
Diethyl ether	-49	1A
Ethanol	55	1B
Heptane	25	1B
Isopropyl Alcohol	53	1B
Methanol	52	1B
Pentane	<-40	1A
Toluene	40	1B

Conditions for a Fire

Improper use of flammable liquids can cause a fire. The following conditions must exist for a fire to occur:

- Flammable material (i.e., fuel) must be present in sufficient concentration to support a fire.
- Oxygen or an oxidizer must be present.
- An ignition source (i.e., heat, spark, etc.) must be present.

When working with flammables, always take care to minimize vapors which act as fuel.

Safe Handling Guidelines for Flammables

- a. Handle flammable chemicals in areas free from ignition sources.
- b. Never heat flammable chemicals with an open flame. Use a water bath, oil bath, heating mantle, hot air bath, hot plate, etc. Such equipment should be intrinsically safe, with no open sparking mechanisms.



NOTE: When using an oil bath, make sure the temperature is kept below the oil flash point.

- c. Use ground straps when transferring flammable chemicals between metal containers to avoid generating static sparks.
- d. Work in an area with good general ventilation and use a fume hood when there is a possibility of dangerous vapors. Ventilation will help reduce dangerous vapor concentrations, thus minimizing this fire hazard.
- e. Restrict the amount of stored flammables in the laboratory, and minimize the amount of flammables present in a work area.

NOTE: The NFPA has established formal limits on the total amounts of flammable liquids that may be stored or used in laboratories. (NFPA 30 and 45)

- f. Only remove from storage the amount of chemical needed for a particular experiment or task.

9.3 SOLVENTS

Organic solvents are often the most hazardous chemicals in the work place. Solvents such as ether, alcohols, and toluene, for example, are highly volatile and flammable.

Perchlorinated solvents, such as carbon tetrachloride (CCl₄), are non-flammable. But most hydrogen-containing chlorinated solvents, such as chloroform, are flammable. When exposed to heat or flame, chlorinated solvents may produce carbon monoxide, chlorine, phosgene, or other highly toxic gases.



Always use volatile and flammable solvents in an area with good ventilation or preferably in a fume hood. Never use ether or other highly flammable solvents in a room with open flames or other ignition sources present, including non-intrinsically safe fixtures.

Solvent Exposure Hazards

Health hazards associated with solvents include exposure by the following routes:

- Inhalation of a solvent may cause bronchial irritation, dizziness, central nervous system depression, nausea, headache, coma, or death. Prolonged exposure to excessive concentrations of solvent vapors may cause liver or kidney damage. The consumption of alcoholic beverages can enhance these effects.
- Skin contact with solvents may lead to defatting, drying, and skin irritation.
- Ingestion of a solvent may cause severe toxicological effects. Seek medical attention immediately.

The odor threshold for the following chemicals exceeds acceptable exposure limits. Therefore, if you can smell it, you may be overexposed — *increase ventilation immediately!* Examples of such solvents are:

- Chloroform
- Benzene
- Carbon tetrachloride
- Methylene chloride

NOTE: Do not depend on your sense of smell alone to know when hazardous vapors are present. The odor of some chemicals is so strong that they can be detected at levels far below hazardous concentrations (e.g., xylene).

Some solvents (e.g., benzene) are known or suspected carcinogens.

Reducing Solvent Exposure

To decrease the effects of solvent exposure, substitute hazardous solvents with less toxic or hazardous solvents whenever possible. For example, use hexane instead of diethyl ether, benzene or a chlorinated solvent.

Solvent Example: DMSO

Dimethyl sulfoxide (DMSO) is unique because it is a good solvent with many water-soluble as well as lipid-soluble materials. Due to these properties, dimethyl sulfoxide is rapidly absorbed and distributed throughout the body.

DMSO can facilitate absorption of other chemicals – such as grease, oils, cosmetics – that may contact the skin.

- While DMSO alone has low toxicity, when combined with other, more toxic chemicals it can cause the more toxic chemical to be absorbed more readily through the skin.
- Some medications, such as liniment, also contain DMSO.

While relatively stable at room temperature, DMSO can react violently to other chemicals when heated.

Wear impervious clothing and personal protective equipment (laboratory coat, gloves, etc.) to prevent skin exposure. Use chemical splash goggles and/or a face shield if splashing may occur.

9.4 TOXINS AND IRRITANTS

The toxicity of a chemical refers to its ability to damage an organ system (kidneys, liver), disrupt a biochemical process (e.g., the blood-forming process) or disrupt cell function at some site remote from the site of contact. Any substance, even water, can be harmful to living things under the right conditions.



The **biological effects** – whether beneficial, indifferent or toxic – of all chemicals are dependent on a number of factors, including:

- Dose (the amount of chemical to which one is exposed)
- Duration of exposure (both length of time and frequency)

- Route of entry:
 - Ingestion
 - Absorption through the skin
 - Inhalation
 - Injection

NOTE: *Inhalation and dermal absorption are the most common methods of chemical exposure in the workplace.*

- Individual response and history
- One's exposure to other chemicals
- Mixing the toxin with other chemicals

The most important factor in toxicity is the dose-time relationship. In general, the more toxin to which an individual is exposed, and the longer they are exposed to it, the stronger their physiological response will be. However, an individual's response can also depend on several other factors, including:

- Health
- Gender
- Genetic predisposition
- An individual's exposure to other chemicals
- Previous sensitization

NOTE: *When a person becomes sensitized to a chemical, each subsequent exposure may often produce a stronger response than the previous exposure.*

- Chemical mixtures

NOTE: *Combining a toxic chemical with another chemical can increase the toxic effect of either or both chemicals.*

IMPORTANT: *Minimize exposure to any toxic chemical.*

General Safe Handling Guidelines

- a. Read the appropriate MSDS.
- b. Be familiar with the chemical's exposure limits.
- c. Use a chemical fume hood.
- d. *Always* wear appropriate PPE.
- e. *Never* eat, drink, or use tobacco products around toxins or store them near any hazardous chemicals.
- f. Avoid touching your face or other exposed skin with contaminated gloves or other contaminated materials.
- g. Store toxic gases in a gas exhaust cabinet.

Acute Toxins vs. Chronic Toxins

The dose-time relationship forms the basis for distinguishing between acute toxicity and chronic toxicity.

The **acute toxicity** of a chemical is its ability to inflict bodily damage from a single exposure. A sudden, high-level exposure to an acute toxin can result in an emergency situation, such as a severe injury or even death. Examples of acute toxins include the following:

- Hydrogen cyanide
- Hydrogen sulfide
- Nitrogen dioxide
- Ricin
- Organophosphate pesticides
- Arsenic

IMPORTANT: Do not work alone when handling acute toxins. Use a fume hood to ensure proper ventilation, or wear appropriate respiratory protection if a fume hood is not available.

Chronic toxicity refers to a chemical's ability to inflict systemic damage as a result of repeated exposures, over a prolonged time period, to relatively low levels of the chemical. Such prolonged exposure may cause severe injury. Examples of chronic toxins include the following:

- Mercury
- Lead
- Formaldehyde

Some chemicals are extremely toxic and are known primarily as acute toxins. Some are known primarily as chronic toxins. Others can cause either acute or chronic effects.

The toxic effects of chemicals can range from mild and reversible (e.g. a headache from a single episode of inhaling the vapors of petroleum naphtha that disappears when the victim gets fresh air) to serious and irreversible (liver or kidney damage from excessive exposures to chlorinated solvents). The toxic effects from chemical exposure depend on the severity of the exposures. Greater exposure and repeated exposure generally lead to more severe effects.

Types of Toxins

Carcinogens are materials that can cause cancer in humans or animals. Several agencies including OSHA (Occupational Safety & Health Administration), NIOSH (The National Institute for Occupational Safety and Health), and IARC (International Agency for Research on Cancer) are responsible for identifying carcinogens. There are very few chemicals known to cause cancer in



humans, but there are many suspected carcinogens and many substances with properties similar to known carcinogens.

Examples of known carcinogens include the following:

- Asbestos
- Benzene
- Tobacco smoke
- Hexavalent Chromium
- Aflatoxins
- Carbon tetrachloride

Zero exposure should be the goal when working with known or suspected carcinogens. Workers who are routinely exposed to carcinogens should undergo periodic medical examinations.

Reproductive toxins are chemicals that can adversely affect a person's ability to reproduce. **Teratogens** are chemicals that adversely affect a developing embryo or fetus. Heavy metals, some aromatic solvents (benzene, toluene, xylenes, etc.), and some therapeutic drugs are among the chemicals that are capable of causing these effects. In addition, the adverse effects produced by ionizing radiation, consuming alcohol, using nicotine and using illicit drugs are recognized.



While some factors are known to affect human reproduction, knowledge in this field (especially related to the male) is not as broadly developed as other areas of toxicology. In addition, the developing embryo is most vulnerable during the time before the mother knows she is pregnant. Therefore, it is prudent for all persons with reproductive potential to minimize chemical exposure.

Sensitizers may cause little or no reaction upon first exposure. Repeated exposures may result in severe allergic reactions.

Examples of sensitizers include the following:

- Isocyanates
- Nickel salts
- Beryllium compounds
- Formaldehyde
- Diazomethane
- Latex

NOTE: *Some people who often use latex-containing products may develop sensitivity to the latex. A sensitized individual's reaction to latex exposure can*

eventually include anaphylactic shock, which can result in death. To minimize exposure to latex, use non-latex containing gloves, such as nitrile gloves.

Irritants cause reversible inflammation or irritation to the eyes, respiratory tract, skin, and mucous membranes. Irritants cause inflammation through long-term exposure or high concentration exposure. For the purpose of this section, irritants do not include corrosives.



Examples of irritants include the following:

- Ammonia
- Formaldehyde
- Halogens
- Sulfur dioxide
- Poison ivy
- Dust
- Pollen
- Mold

Mutagens can alter DNA structure. Some mutagens are also carcinogens. Examples of mutagens are:

- Ethidium bromide
- Nitrous acid
- Radiation

Neurotoxins are chemicals that affect the nervous system. Examples of neurotoxins include:

- Methanol
- Many snake and insect venoms
- Botulinum toxin

9.5 REACTIVES AND EXPLOSIVES

Reactive chemicals may be sensitive to either friction or shock, or they may react in the presence of air, water, light, heat, or other chemicals. Some reactive chemicals are inherently unstable and may quickly decompose on their own, releasing energy in the process. Others form toxic gases when reacting. **Explosive chemicals** decompose or burn very rapidly when subjected to shock or ignition. Reactive and explosive chemicals produce large amounts of heat and gas when triggered, and thus are extremely dangerous.



Follow these guidelines when handling and storing reactive and explosive chemicals:

- a. Read the appropriate MSDS and other pertinent fact sheets on the chemical. Be familiar with chemical specific handling and storage requirements.
- b. Follow Standard Operating Procedures and to have a Plan of Action established for how to handle emergency situations.
- c. Isolate the chemical from whatever causes a reaction.
 - i. Store reactives separate from other chemicals.
 - ii. Store reactives in a cool/dry area.
 - iii. Keep reactive chemicals out of sunlight and away from heat sources.
- d. Know where emergency equipment is located and how to use it.

Examples of reactive compounds include the following:

REACTIVE CLASSIFICATION	CHEMICAL EXAMPLES
Acetylenic compounds	Acetylene Copper(I) acetylide
Azides	Benzenesulfonyl azide Lead (II) azide
Azo compounds	Azomethane Diazomethane
Chloro/perchloro compounds	Lead perchlorate Potassium chlorite Silver chlorate Perchloric Acid (Anhydrous)
Fulminates	Copper (II) fulminate Silver fulminate
Nitro compounds	Nitromethane Trinitrotoluene (TNT)
Nitrogen-containing compounds	Silver amide Silver nitride
Organic peroxide formers	Diethyl ether Isopropyl ether
Picrates	Picric acid (dry) Lead picrate
Peroxides	Diacetyl peroxide Zinc peroxide
Strained ring compounds	Benzvalene Prismane

Polymerizable compounds	Butadiene Vinyl chloride
-------------------------	-----------------------------

SECTION 10: PROTECTING ONESELF WHEN WORKING WITH CHEMICALS

For information on ways to protect oneself when working with chemicals, including information on personal protective equipment, engineering controls, and how to respond to chemical spills and exposures, see [Chapter 6](#) of this manual, which is titled, "How to Protect Yourself."

SECTION 11: CHEMICAL WASTE DISPOSAL

Chemical waste must be disposed of as hazardous waste. For information on chemical waste disposal, contact the Office of EH&S.

SECTION 12: TRANSPORTING HAZARDOUS MATERIALS

The U.S. Department of Transportation (DOT) and the International Air Transportation Association (IATA) regulates the shipment of hazardous materials. Anyone who packages, receives, unpacks, signs for, or transports hazardous chemicals must be trained and certified in Hazardous Materials Transportation. Warehouse personnel, shipping and receiving clerks, truck drivers, and other employees who pack or unpack hazardous materials must receive this training as well. Contact EHS for more information on shipping and receiving hazardous chemicals.

XIV. AGRICULTURE SAFETY

1.0 Introduction to Agricultural Safety

- 1.1 The following information provides information on tractor safety, pesticide and chemical safety, and fertilizer safety.
- 1.2 Agriculture workers are exposed to many different work environments and potential hazards in agricultural activities such as operating agricultural equipment or heavy machinery, applying pesticides and other chemicals, and handling livestock. This manual will not only help in identifying hazards associated with agriculture work activities, but also help reduce exposure to those risks for a more safe and healthy agricultural work environment.
- 1.3 In work-related fatality rates among U.S. industries, agriculture ranks first. It is one of the most hazardous occupations in the United States. A majority of agricultural accidents involve some type of machinery or equipment. Accidents cost time, money, and involve intangible losses. Time will be lost while you are recovering, medical and rehabilitation bills will begin to add up, and, worst of all, you might not be able to function as you did before the accident. Safety is too expensive not to be taken seriously. Accident costs reduce the profit margin of your operation and, in the worst cases, accidents cost people their lives.
- 1.4 Safety is everyone's responsibility. It is up to everyone associated with the agricultural industry to use safe working practices. All employees can contribute to each others' safety.
- 1.5 Remember, operators of machinery aren't the only ones who get hurt in agricultural accidents.

2.0 General Tips for a Safe Working Environment:

- 2.1 For an effective farm or ranch safety program, first perform a safety status assessment.
- 2.2 Make safety everyone's concern including family, employees, visitors, and yourself.
- 2.3 Be aware of what you are doing and your surroundings. The highest percentages of injuries happen during routine, 'every day' chores.
- 2.4 Ask for help if a task might be more than you can handle alone.
- 2.5 Take short rest breaks, so you don't overexert yourself.
- 2.6 Eat a well balanced diet and get plenty of sleep.
- 2.7 Stay away from equipment if you are angry. Wait a little while until you cool down.
- 2.8 Train new equipment operators before letting them work on their own.
- 2.9 Read the operator's manuals for all equipment.
- 2.10 Wear the proper personal protective equipment (PPE) for 'every day' chores and for specific jobs. Protective footwear, that also provides ankle support, and close

fitting clothing are important for 'every day' work. (Specific job related PPE is discussed in the following modules).

3.0 Remember the Following Points

- 3.1 Agriculture is the leading industry for work related accidents.
- 3.2 Safety is everyone's responsibility.
- 3.3 Safety is too expensive to learn by accident. Accidents have many related costs.
- 3.4 Working environment safety can be improved by following a few simple safety measures.

4.0 General Farm Equipment Safety

- 4.1 Newer farm equipment incorporates specific design features to enhance safe handling and operation. Older farm equipment may lack these features, and additional caution is warranted when operating older equipment. Never disable safety devices or controls on farm equipment.
- 4.2 The following sections discuss general guidelines for farm equipment safety, including farmstead equipment, farm field equipment, guards, shields, and power take-off equipment (PTOs).
 - 4.2.1 Keeping equipment in good working condition is half the formula for being safe. The other half is the ability and awareness of the person operating the equipment.
 - 4.2.2 Safety = Good Working Equipment + Able and Aware Operator
 - 4.2.3 Equipment failure causes some farm accidents; however, most farm accidents are caused by tired, stressed, rushed, distracted, or incompetent operators.
- 4.3 In addition to the specific safe handling rules for each type of farm equipment, there are ten basic guidelines for equipment safety:

- 4.3.1 Read and comply with the operator's safety manual for each piece of farm equipment.
- 4.3.2 Prepare for safety by wearing appropriate clothing, having enough rest, not drinking alcohol, and ensuring that all workers have been trained and are capable of safely using the farm equipment.
- 4.3.3 Keep all guards, shields, and access doors in place when the equipment is in operation.
- 4.3.4 Be aware of what you are doing and where you are going.
- 4.3.5 Adjust equipment speed to fit operating conditions.
- 4.3.6 Keep children and other people away from the working area.
- 4.3.7 Take breaks from work, as necessary.



- 4.3.8 Always stop the engine, disconnect the power source, and wait for all moving parts to stop, before servicing, adjusting, cleaning, or unclogging equipment.
- 4.3.9 Display the slow moving vehicle emblem on equipment driven on public roadways
- 4.3.10 Allow the engine to cool before refueling.



5.0 Farmstead Equipment

- 5.1 Farmstead equipment is agricultural machinery that is normally stationary. This includes materials handling equipment and accessories for such equipment whether or not the equipment is an integral part of a building. Examples of farmstead equipment include cotton gins, grain augers, crushers, sorters, and miscellaneous belt-driven equipment.
- 5.2 Farmstead equipment should have an audible warning device to indicate that the machine is about to be started. Refer to Electrical Lockout/Tagout procedures (Chapter 5) to safely perform repairs or maintenance on electrical equipment. Farmstead equipment that is not properly guarded and shielded may pinch, crush, electrocute, or otherwise harm humans. Refer to the operator's manual for specific safety instructions for each piece of equipment.

6.0 Farm Field Equipment

- 6.1 Farm field equipment is agricultural machinery that is normally mobile. Examples of farm field equipment include combines, tractors and their implements, including self-propelled implements. Because tractor accidents account for 500 to 600 fatalities each year, this section will focus primarily on tractor safety.

7.0 Grain Augers

- 7.1 A grain auger is a piece of farm equipment that helps transfer grain from one location to another. Tractor operators that move grain augers should take special precautions when working with this equipment.
- 7.2 **IMPORTANT:** *Moving grain augers in their elevated position may result in electrocution if the equipment contacts overhead power lines.*
- 7.3 Farm owners, managers, and operators should ensure that augers are in the lowered position before moving them. In addition, all augers should have warning signs that indicate the potential electrical hazards associated with moving the auger upright. Functional components of augers must be guarded to the fullest extent possible.

8.0 Hydraulic Equipment Safety

- 8.1 Farm equipment operators must be extremely careful when working around hydraulic equipment. Hydraulic pressure is often strong enough to knock a person out if a leak or explosion occurs.
- 8.2 Follow these guidelines when working with hydraulic equipment:
- 8.2.1 Inspect hydraulic equipment regularly for leaks. Report and fix any leaks immediately.
 - 8.2.2 Ensure that all couplings are properly installed and in good working condition.
 - 8.2.3 Ensure that all lines and fittings are in good condition. Repair or replace any equipment that is not in good condition.
 - 8.2.4 Lock transport wheels and support jacks on implements in place before disconnecting hydraulic cylinders. This action will prevent sudden shocks to the machine or personal injury.
 - 8.2.5 Keep couplings and hoses in good repair so that the hydraulic system can safely sustain maximum pressure.



9.0 Guards, Shields, and PTOs

- 9.1 Guards and shields are extremely important because they keep operators from inadvertently contacting, or being caught, by moving machinery parts. Ensure that moving parts are guarded or shielded whenever possible. In addition, to prevent burns or fires, shield heat-producing components (e.g., exhaust pipes).
- 9.2 Since all moving parts cannot be guarded due to their function, stay clear of these machines when they are in operation. In addition, turn these machines off if they need service, maintenance, or repair.
- 9.3 **IMPORTANT:** *If you take guards or shields off, put them back on the machine. Replace them if they are lost or damaged.*
- 9.4 Guards and shields are absolutely essential for PTO farm equipment. Leave the master shield in place when the implement is unhitched. Replace missing or damaged shields immediately.

10.0 Fuel Storage

- 10.1 Fuel storage is an important safety concern in agriculture. The following sections discuss general safety guidelines for stationary fuel storage tanks, portable fuel tanks, and liquefied petroleum gas.

11.0 Stationary Fuel Storage Tanks



11.1 Petroleum products for agricultural use, including gasoline and diesel fuel, are stored in Aboveground Storage Tanks (AST) or Underground Storage Tanks (UST). The Texas Commission on Environmental Quality (TCEQ) regulates ASTs and USTs. Fuel tanks with volumes less than or equal to 1100 gallons are exempt from TCEQ requirements. Fuel tanks with volumes greater than 1100 gallons must meet these requirements:

- 11.1.1 Notification
- 11.1.2 Registration
- 11.1.3 Annual fees
- 11.1.4 Recordkeeping

12.0 Portable Fuel Tanks

12.1 Even small quantities of fuel, such as gasoline, kerosene, or diesel fuel must be properly labeled and stored. Always use DOT approved metal tanks or UL or FM labeled containers to store small amounts of fuel. Store small portable fuel tanks in well-ventilated areas, away from other flammable materials or ignition sources. Do not use containers such as empty plastic milk jugs to store fuels. Please refer to the Chemical Safety chapter for more information on flammable materials.



12.2 **IMPORTANT:** Clearly label fuel containers to indicate contents.

13.0 Liquefied Petroleum Gas

13.1 The Texas Railroad Commission regulates the sale and use of Liquefied Petroleum Gas (LPG). There are several safety considerations associated with LPG. All LPG tanks must comply with Department of Transportation (DOT) standards for storage and use. Paint LPG tanks either white or aluminum. Locate LPG tanks away from flammable materials and possible ignition sources. In addition, ensure that ASTs have noncombustible structural supports and a firm masonry foundation so that the bottom of the tank does not touch the ground.



13.2 LPG tanks cannot be downhill from flammable liquid tanks such as gasoline or diesel. Stationary LPG tanks cannot be placed in any area beneath an electric transmission or distribution line.

13.3 LPG tanks must be equipped with hydrostatic relief valves, excess flow valves, etc, as required by the Texas Railroad Commission.

13.4 **IMPORTANT:** Portable LPG containers may be used within a building; however, they must be stored in a separate location outside of the building. Refer to the Fire/Life Safety chapter for more information.

13.5 The following table provides minimum safe distance requirements for the location of stationary LPG containers.

Location Description	0-500.99 Gallons	501-2000.99 Gallons	2001-4000.99 Gallons
	Minimum Safe Distance		
Ignition Source/Combustible Material	10 feet	15 feet	25 feet
Flammable Liquid Container	20 feet	20 feet	20 feet
Building	10 feet	15 feet	25 feet
Adjoining Property line	10 feet	15 feet	25 feet
Roadway, Railway, Utility Line, or Pipe Line	10 feet	15 feet	25 feet

14.0 Grain Storage

14.1 Grain storage bins and hoppers pose severe hazards, including entrapment and suffocation. Each year, numerous people suffocate and die while working on or under the unstable materials contained in grain silos. Grain materials are unpredictable and they move quickly — entrapment, burial, and suffocation can occur within seconds.



14.2 In some cases, the surface material in a grain bin acts like quicksand. When a storage bin is emptied from the bottom, the grain material forms a funnel. The flow rate of this funnel can be strong enough to trap a worker and make rescue virtually impossible.

14.3 In other cases, a condition known as bridging can create serious hazards. A bridge occurs when grain or other loose material sticks to the side of a bin that is being emptied from below. The bridge is highly unstable and dangerous. If it collapses, it can trap any worker either on or below it.

14.4 Follow these guidelines to reduce the risks associated with grain storage:

14.4.1 Assume that all stored materials are bridges and that the potential for entrapment and suffocation is constant.

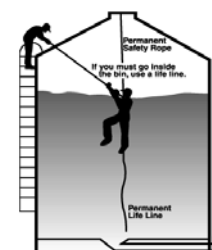

- 14.4.2 Do not enter a storage area from the bottom if material is adhering to the sides.
- 14.4.3 If you must enter a storage area, use a safety belt or harness with a lifeline. Always stay above the highest level of material. Never stand on top of stored material.
- 14.4.4 Lock out supply and discharge equipment whenever a worker enters the storage area.
- 14.4.5 Post signs that indicate the hazards of working with stored materials.

15.0 GENERAL TRACTOR SAFETY

15.1 Tractor accidents are the leading cause of fatalities and accidents on Texas farms and ranches. Approximately 42% of these accidents are the result of operators being run over by tractors, 36% are due to tractor roll-overs, and 5% involve riders who fall off the tractor and are then run over by the attached trailing equipment.



15.2 The following guidelines offer general safety tips for operating tractors:

- 15.2.1 Know your tractor and how to use it safely. Regularly review the safety precautions in your operator's manual.
- 15.2.2 Prepare for tractor work by inspecting the vehicle and wearing appropriate clothing.
- 15.2.3 Ensure that new and inexperienced workers are properly trained in tractor operation.
- 15.2.4 Never allow riders. A tractor should have only one person on board.
- 15.2.5 Install an approved roll-over protective structure (ROPS) and seat belt on any tractor that is not equipped with these features. ROPS prevent tractor turnover injuries, but only if the seat belt is worn.
- 15.2.6 Always wear a seat belt, when driving a tractor equipped with a ROPS.
- 15.2.7 Disengage drives and turn the engine off before leaving the tractor unattended.
- 15.2.8 Keep yourself and others away from moving parts.
- 15.2.9 Hitch loads only to the drawbar. When using three-point rear hitches, add front end weights to maintain stability and control steering.
- 15.2.10 Never bypass start the engine.

16.0 Tractor Driving Safety

16.1 Accidents usually occur because highway safety precautions are not followed. Therefore, tractors shall not be driven on highways or public roadways.

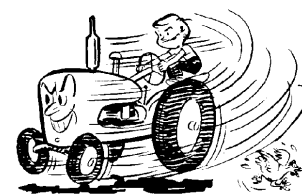

- 16.2 Vehicles traveling on public roads at 25 mph or less are legally required to have a slow-moving vehicle sign attached. Equipment traveling faster than 25 mph is defined as a trailer and is not permitted to display the SMV emblem, but must be equipped with turn signals, brakes, and lights. Lighting regulations for slow-moving vehicles vary. Before installing any warning light system on a tractor, check the regulations. Generally the lighting and marking laws for tractors or self propelled machines are consistent with the recommendations by the American Society of Agricultural Engineers (ASAE) and the Society of Automotive Engineers (SAE). Only one vehicle classified as farm machinery may be towed by the licensed motor vehicle.
- 16.3 Lights and emblems must be clearly visible. If lights or emblems are blocked during towing, attach lights and emblems to the rear of the implements. Most tractors can be equipped with auxiliary connectors allowing implement electrical systems to be plugged into the circuit operating the tractor lights.
- 16.4 ASAE recommendations include:
- 16.4.1 Two headlights
 - 16.4.2 At least one tail lamp, mounted on the left side facing the rear of the tractor
 - 16.4.3 At least two amber warning lights, visible from front and rear, mounted at the same level at least 42 inches above ground level.
 - 16.4.4 At least two red reflectors, visible from the rear and mounted on either side.
 - 16.4.5 Before use remember:
 - 16.4.5.1 Lock brake pedals
 - 16.4.5.2 Adjust mirrors for good vision
 - 16.4.5.3 Make sure that all warning flashers, lights, and SMV emblems are in proper operating condition, clean, and easily visible
 - 16.4.5.4 Check tire inflation pressures. Inflate the tires to the maximum recommended pressure for long distance travel
 - 16.4.5.5 Check the wheels to see if the bolts are tight
 - 16.4.5.6 Make sure the tractor is balanced properly
 - 16.4.6 Tractors do not accelerate rapidly, especially when towing equipment
 - 16.4.7 When traveling:
 - 16.4.7.1 Watch for pot holes or obstacles that could tip tractor

- 16.4.7.2 Listen for cars. Often vehicles will rapidly approach from the rear at 3 to 4 times the speed of the tractor
- 16.4.7.3 Stay alert at all times to avoid a serious accident
- 16.4.7.4 Keep a constant lookout for pedestrians, animals, and road obstacles
- 16.4.7.5 Slow down for sharp curves.
- 16.4.7.6 Slow down when going down a hill

16.4.8 Tractor operators can help prevent back roll-overs as follows:

- 16.4.8.1 Only hitch loads to the drawbar
- 16.4.8.2 Limit the height of three-point hitches
- 16.4.8.3 Use front-end weights to stabilize heavy hauling loads
- 16.4.8.4 Start slowly
- 16.4.8.5 Change gears carefully

16.4.9 Tractor operators can help prevent side roll-overs as follows:

- 16.4.9.1 Increase tractor width, if possible
- 16.4.9.2 Lock brakes together for road travel
- 16.4.9.3 Operate tractors only as recommended
- 16.4.9.4 Avoid steep slopes and ditches
- 16.4.9.5 Be careful when pulling heavy loads or working with a front-end loader
- 16.4.9.6 Turn corners slowly

16.4.10 Remember the Following Points

- 16.4.10.1 Know the Law concerning highway travel for tractors
- 16.4.10.2 Watch for highway traffic
- 16.4.10.3 Use common sense and obey traffic patterns when traveling

16.5 The following guidelines provide tips for driving tractors safely:

- 16.5.1 Watch where you are going at all times. Be sure everyone is out of the way before moving.
- 16.5.2 Watch for and avoid obstacles, ditches, embankments, and holes.
- 16.5.3 Slow down when turning, crossing slopes, or driving on rough, slick, or muddy surfaces.
- 16.5.4 It is safer to back up an incline.
- 16.5.5 Apply power slowly when pulling a heavy load.
- 16.5.6 Lock the brake pedals together for single action braking.

17.0 Roll-over Protective Structures (ROPs)

17.1 Tractor rollovers account for 50% of tractor related fatalities in the United States. Distracted operators, speed, and rough or uneven ground are leading causes of tractor rollover. Rollover protective structures (ROPS) became available for tractors in the mid 1960's and were not available for all new tractors until the mid-70's. However, they were not standard equipment on new tractors until 1985. Many tractors built before that time are still in use and contribute to the tractor fatality rate because they are not ROPS and seat belt equipped. Use of ROPS and seatbelt are 99.9% effective in preventing deaths due to tractor overturns.



17.2 *OSHA requires ROPS and seatbelts to be installed on all tractors operated by employees*

17.3 There are two types of rollover protective structures:

- 17.3.1 Rollover Protective Frame
- 17.3.2 Rollover Protective Enclosure

17.4 Rollover Protective Frame

17.4.1 These are either two or four post frames which are securely mounted to the main body of the tractor. Use the provided seat belt to keep the operator within the protected area

17.5 Rollover Protective Enclosure

17.5.1 A rollover protective enclosure utilizes the protective frame, but totally encloses the frame with metal and glass. Seat belts are provided and must be used to contain the operator within the protected area. In addition, this cab enclosure gives protection from weather, dust, noise and vibration. Enclosures on older tractors were designed for operator comfort not for rollover protection and they are not considered ROPS. ROPS must meet regulations and standards that certify that they provide adequate protection in a tractor rollover. To find out if a frame or enclosure is certified, look for a certification label, contact the manufacturer, or check for the presence of a manufacturer installed seatbelt

17.6 Reducing the risk of a side rollover:

- 17.6.1 Set wheels as far apart as possible
- 17.6.2 Lock the brake pedals together before high speed road travel

- 17.6.3 Match speed to operating conditions and loads. Do not let the front wheels bounce
- 17.6.4 Slow down before turning.
- 17.6.5 Use engine braking when going downhill
- 17.6.6 Avoid crossing steep slopes. Watch for depressions on the downhill side and bumps on the uphill side. Turn downhill, not uphill, if stability becomes a problem.
- 17.6.7 Stay at least as far from ditches and rivers as banks are deep
- 17.6.8 Keep front-end loader buckets as low as possible when moving
- 17.6.9 If right front tire goes off the road into the ditch--turn downward rather than attempting to turn back onto the roadway

17.7 Reducing the risk for rear overturn:

- 17.7.1 Always hitch loads at the drawbar
- 17.7.2 Use front weights to increase tractor stability
- 17.7.3 Start forward motion slowly and change speed gradually
- 17.7.4 If possible, avoid backing downhill
- 17.7.5 Drive around ditches.
- 17.7.6 Back out or be towed out of ditches or mud

17.8 Review The Following Points

- 17.8.1 Install and use seat belts on tractors with ROPS
- 17.8.2 ROPS do not prevent rollovers from occurring
- 17.8.3 Most rollovers involve tractor speed, operator error, or unsafe driving conditions
- 17.8.4 Follow safety steps to prevent rollovers

17.9 **Always wear a seat belt, when driving a tractor equipped with a ROPS.**

17.10 Tractors that do not require ROPS include the following:

- 17.10.1 Low profile tractors used for work that would interfere with a ROPS (e.g., picking orchards, vineyards, hopyards, etc.).
- 17.10.2 Tractors with mounted equipment that is incompatible with a ROPS (e.g., cornpickers, cottonstrikers, fruit harvesters, etc.)

18.0 Bypass Starting

- 18.1 Bypass starting occurs when an operator "bypasses" normal safety procedures and the normal starting system. A typical bypass occurs when someone standing on the ground touches a screwdriver or other metal object to the starter contacts and activates the engine. This action avoids standard safety devices that keep the engine from starting without someone in the driver's seat. Another method of

bypass starting occurs when someone uses the starting button to start a tractor from the ground.

- 18.2 **IMPORTANT:** *Any method of bypass starting is extremely dangerous. If the tractor is in gear when the bypass occurs, the machine will start and can injure or kill anyone in its path. This situation is even more serious if the tractor is equipped with a hydraulic clutch. If a tractor with a hydraulic clutch is bypass started, it will not move immediately, but it will lurch suddenly with the buildup of hydraulic pressure.*



- 18.3 All tractor operators should follow these safe starting rules:

- 18.3.1 Never start a tractor by shorting across the starter terminals.
- 18.3.2 Keep tractors in good working order so they will start normally.
- 18.3.3 If a tractor has a neutral start switch, but it starts in gear with the key or starter button, something is wrong. Fix the tractor immediately.
- 18.3.4 Never wire around or defeat the neutral start switch.
- 18.3.5 Always place a tractor in neutral or park before starting it.
- 18.3.6 Never start a tractor from the ground.

19.0 Towing Safety

- 19.1 When towing a trailer or farm equipment, follow these guidelines to ensure driving safety:

- 19.1.1 Ensure that the trailer and hitching attachments meet local and state requirements. The trailer must have a current tag and registration.
- 19.1.2 Inspect the trailer and the towing vehicle's wheels and lights to ensure they are in good working order.
- 19.1.3 Ensure that the trailer hitch is sufficiently strong and properly mounted.
- 19.1.4 Make sure that the towing ball is the correct size for the trailer hitch.
- 19.1.5 Always secure a safety chain between the trailer and the towing vehicle.
- 19.1.6 Inspect all indicator lights to ensure they are working.
- 19.1.7 Adjust mirrors as necessary to view the roadway behind the trailer.
- 19.1.8 Adjust your speed and apply brakes evenly to allow for increased stopping distances.
- 19.1.9 When backing a trailer, it is helpful to have another person behind the trailer to guide you. Put your hand on the bottom section of the



steering wheel and turn the wheel in the direction that you want the trailer to move.

20.0 Tractor Hauling Safety

20.1 When hauling a tractor for some distance, it is best to transport it on a truck or trailer.

20.1.1 Safe highway procedures for hauling include:

20.1.1.1 Haul tractors and implements on a flatbed.

20.1.1.2 Obey the laws for height, width and tie-down regulations.

20.1.1.3 Remove, cover or turn SMV signs when tractors are transported on another vehicle.

20.1.1.4 Use the correct flags, lights, and reflectors on the transport vehicle to warn other drivers.

20.1.1.5 For shorter distances, tractor highway travel is appropriate. For the safety of everyone on the road, safety provisions should always be followed. Only operate machinery in good repair on the highway. Properly hitch implements with adequate safety chains before beginning the journey, and never use makeshift hitch pins.

21.0 Pesticide Chemical Safety

21.1 Texas A&M International University uses a third party-contractor for pesticide application. If pest services are needed, please submit online work order. **The use of pesticides, including over the counter products, may not be used by TAMIU employees.**

21.2 This section discusses agricultural chemical safety for pesticides, including rodenticides, insecticides, herbicides, etc. Pesticides are chemicals that protect crops and livestock from rodents, insects, disease, or weeds. They also control pests that endanger human health. Because pesticides are poisonous, they can be extremely dangerous to humans. Before applying commercial pesticides, always ensure your safety, the safety of others, and the safety of the environment.

21.3 There are four ways toxic materials can be taken into the body. They are: oral, dermal, inhalation, and ocular exposures, with dermal being the most common type of exposure. These types of exposures are explained in Table 13.1.

TABLE 13.1

Type of Exposure	Definition	Cause of Exposure
Oral Exposure	Swallow or ingest a	<ul style="list-style-type: none"> • Not washing hands before eating, drinking, smoking or chewing tobacco. • Mistaking a pesticide for food or drink.

		<ul style="list-style-type: none"> • Accidentally applying pesticides to food. • Splashing pesticide into the mouth through carelessness or accident.
Dermal Exposure	Having pesticide on your skin	<ul style="list-style-type: none"> • Not washing hands after handling pesticides or their containers. • Splashing or spraying pesticides on unprotected skin. • Applying pesticides in windy weather. • Wearing inadequate personal protective equipment while handling pesticides or their containers.
Inhalation Exposure	Breathing in a pesticide.	<ul style="list-style-type: none"> • Prolonged contact with pesticides in closed or poorly ventilated spaces. • Breathing vapors from fumigants and other pesticides. • Breathing vapors, dust, or mist while handling pesticides without appropriate protective equipment. • Inhaling vapors immediately after a pesticide is applied. • Using the wrong respirator, or an improperly fitted respirator, or using filters, cartridges, or canisters that are "full" of chemicals, dust, etc.
Ocular Exposure	Pesticide gets in the eye.	<ul style="list-style-type: none"> • Splashing or spraying pesticides in eyes. • Applying pesticides in windy weather without eye protection. • Rubbing eyes with contaminated gloves or hands. • Pouring dust, granules or powder formulations without eye protection.

21.4 Exposure is considered:

- 21.4.1 Acute: One-time case of pesticide exposure. For example: a spill on the body. Exposure is usually easy to determine
- 21.4.2 Chronic: Low-level exposure over a longer period of time. Exposure is usually difficult to determine
- 21.4.3 A combination of the two exposures can be dangerous. For example, daily exposure to a pesticide through contaminated clothing combined with an acute exposure like spilling a pesticide on your skin poses the greatest risk because the body may not be able to deal with the acute exposure

21.5 Avoiding Exposure

21.5.1 In order to avoid exposure, it is important to avoid the causes of exposure. For example, by wearing the proper eye protection you can prevent a pesticide from getting in the eyes

21.5.2 To avoid exposure:

21.5.2.1 Wear proper personal protective equipment

21.5.2.2 If you do start to breathe pesticide mist or dust, move away from that area as quickly as possible and get into fresh air

21.5.2.3 Use a closed handling system

21.5.2.4 Maintain and clean personal protective equipment

21.5.2.5 Wash exposed body parts often to reduce dermal exposure

21.5.2.6 Read pesticide labels thoroughly

21.6 Review the Following Points

21.6.1 Dermal exposure to a pesticide means that it gets on the skin

21.6.2 Ocular exposure to a pesticide means that it gets in the eye

21.6.3 Oral exposure to a pesticide is swallowing or ingesting it

21.6.4 Inhalation exposure is inhaling a pesticide

21.6.5 Using improper personal protective equipment can lead to exposure to the pesticide

21.7 There are several government agencies that govern the use of commercial pesticides. For more information on pesticide usage, contact one or more of the following groups: Texas Department of Agriculture, Texas Department of Health, Texas Structural Pest Control Board, Texas Commission on Environmental Quality (TCEQ), and Environmental Protection Agency (EPA).

22.0 General Pesticide Safety

22.1 The following sections provide general or specific guidelines for handling pesticides. To help reduce the hazards associated with pesticides:

22.1.1 Do not transport, mix, or use agricultural chemicals unless you can summon help, if needed.

22.1.2 Keep an ample supply of water nearby to flush exposed areas, if a spill occurs.

22.1.3 Check all pesticide equipment before you use it to ensure proper working condition.

22.1.4 Read pesticide labels carefully. Follow the label directions when mixing, applying, storing, or disposing of pesticides.

22.1.5 Wear personal protective equipment to prevent dermal, inhalation, and mucous membrane exposure.

22.1.6 Do not eat, drink, or smoke when handling pesticides.

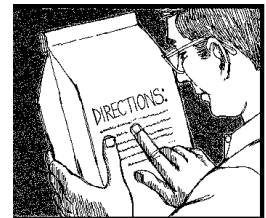

- 22.1.7 Launder clothing and bathe after working with pesticides to ensure that all chemicals are removed from clothing and skin.
- 22.1.8 Do not use agricultural pesticides around the home or office.
- 22.1.9 Observe assigned reentry intervals. Always wear the appropriate protective clothing when entering fields before the reentry date.
- 22.1.10 Always handle pesticides downhill from wells, cisterns, sink holes, ditches, or standing water.
- 22.1.11 Do not apply pesticides when rain is imminent or if wind could affect the spraying area.
- 22.1.12 Triple-rinse spray equipment and empty containers. Apply the rinse water to the treated field.
- 22.1.13 Properly dispose of empty containers.



23.0 Preparing to Apply Pesticides

- 23.1 Preparation is essential for chemical safety. Follow these steps to properly prepare for pesticide application:



- 23.1.1 Plan Ahead.
 - 23.1.1.1 Always read chemical labels before attempting to work with pesticides. Prepare for a possible emergency by maintaining a personal decontamination site, a chemical spill kit, and by knowing the proper first aid procedures associated with your pesticide.
- 23.1.2 Move Pesticides Safely.
 - 23.1.2.1 Careless chemical transportation can cause spills and contamination. Do not carry pesticides in an enclosed area, such as a car. Be sure to secure the pesticides to prevent shifting or bouncing. In addition, never leave your vehicle unattended when transporting chemicals.
- 23.1.3 Select Appropriate Personal Protective Equipment.
 - 23.1.3.1 Regardless of the pesticide's toxicity, always wear a long-sleeve shirt and pants when working with pesticides. Wear additional protective equipment, as necessary.
- 23.1.4 Select Application Equipment.
 - 23.1.4.1 Choose suitable equipment to properly apply pesticides. Before using the equipment, inspect it for good working order.
- 23.1.5 Provide Prior Notification.

- 23.1.5.1 Before applying pesticides, inform all people in or around the application area. Notification allows people to protect themselves from harmful chemicals.

24.0 Mixing Pesticides

- 24.1 Always read and carefully follow label directions when mixing pesticides. Even if you are familiar with a particular chemical, reread the label to ensure that you have the latest safety information. In addition, follow these guidelines for mixing pesticides:



- 24.1.1 Wear Personal Protective Equipment.
 - 24.1.2 Always wear protective gear when handling hazardous chemicals.
- 24.2 Work in a Safe Area.
 - 24.2.1 The pesticide mixing and loading area should be well ventilated, well lighted, and downhill from any water sources. Concrete slabs are ideal for mixing chemicals since they allow for easy cleanup.
- 24.3 Measure Chemicals Correctly.
 - 24.3.1 Measure and mix pesticides carefully. Never mix different pesticides except as directed by the label or chemical manufacturer. Do not use more chemical than prescribed by the pesticide label. The overuse of pesticides is illegal, and may result in the following:
 - 24.3.1.1 Higher pest control costs
 - 24.3.1.2 Pesticide residue in food
 - 24.3.1.3 Groundwater pollution
 - 24.3.1.4 Pesticide resistance

- 24.4 Pour Pesticides Carefully.

- 24.4.1 Always wear a face shield and take care not to splash chemicals when pouring pesticides. Never use your mouth to siphon pesticides.



25.0 Applying Pesticides

- 25.1 When you apply pesticides, you are responsible for protecting yourself, other people, and the environment. Follow these guidelines when applying pesticides:

- 25.1.1 Minimize Exposure.

25.1.1.1 Even mildly toxic chemicals can harm you if you use them daily. Take care to minimize your exposure to any chemical. Avoid working in pesticide spray, mist, or runoff. Always work with another person when working with hazardous chemicals.

25.1.2 Avoid Applying Pesticides in Sensitive Areas.

25.1.2.1 Avoid spraying pesticides near beehives or areas that humans normally occupy (e.g., schools, playgrounds, hospitals, etc.). If you must apply pesticides in sensitive areas, do so when the weather is calm and when people are not around.

25.1.3 Avoid Pesticide Drift, Runoff, and Spills.

25.1.3.1 Pesticides that fall outside the targeted application area can be very hazardous. Choose weather conditions, equipment, and chemicals that do not lend themselves to these hazards.

25.1.4 Avoid Equipment Accidents.

25.1.4.1 Equipment accidents are often caused by poor maintenance and improper work habits. Avoid equipment accidents by following all operating instructions.

26.0 Pesticide Storage and Disposal

26.1 Always try to use all the pesticide in your application tank. If pesticides remain, use them on other target locations. After emptying the tank, clean and store the equipment.

26.2 The following summary of EPA storage criteria should be followed for pesticides labeled with the signal words DANGER, POISON, or WARNING, or the skull and crossbones symbol. These procedures and criteria are not necessary for the storage of pesticides classed as less toxic (CAUTION word on the label) or for those registered for use in the home or garden.

27.0 Site Storage:

27.1 Locate where flooding is unlikely.

27.2 Locate where runoff will not contaminate any water system.

28.0 Storage Facility:

- 28.1 Dry, well ventilated, separate room, building, or covered area with fire protection (e.g., dry chemical fire extinguisher).
- 28.2 Secured by fence and/or locked doors.
- 28.3 Signs on rooms/buildings to provide hazard warning (e.g., DANGER, POISON, PESTICIDE STORAGE).
- 28.4 Movable pesticide equipment is labeled as contaminated and not removed from the site until decontaminated.
- 28.5 Provision is available for the decontamination of personnel and equipment; contaminated water disposed of as excess pesticide; contaminated runoff collected and treated as excess pesticide.



29.0 Operational Procedures:

- 29.1 Store pesticide containers in rows with the labels plainly visible.
- 29.2 Place contents from damaged containers in sound containers.
- 29.3 If relevant, segregate pesticides by formulation.
- 29.4 Store rigid containers in an upright position, with tight lids/bungs, off the ground, in a manner to permit access and inspection.
- 29.5 Maintain a complete inventory indicating the number and identity of containers.
- 29.6 Check containers regularly for corrosion and leaks.
- 29.7 Keep suitable absorbent (e.g., vermiculite) on hand in case of spills.



30.0 Safety Precautions:

- 30.1 Inspect pesticide containers for leaks before handling them.
- 30.2 Do not allow unauthorized personnel in the storage area.
- 30.3 Do not store pesticides next to items intended for consumption by animals or humans.
- 30.4 Do not eat, drink, smoke, or chew tobacco where pesticides are present.
- 30.5 Do not store beverages, food, eating utensils, or smoking material in the storage or loading areas.
- 30.6 Wear rubber gloves while handling containers of pesticides.
- 30.7 Wash hands immediately after handling pesticides. Remove contaminated protective clothing immediately; extra sets of clean clothing should be nearby.



31.0 Fire Control:

- 31.1 Where large quantities are stored, inform the fire department.
- 31.2 Furnish the fire chief with home telephone numbers of responsible persons.

32.0 Disposal:

- 32.1 Unused or outdated pesticides must be disposed as hazardous chemicals.
- 32.2 See the Hazardous Waste Disposal chapter for more information.
- 32.3 **IMPORTANT:** *Never leave pesticide containers at a field site. Be sure to account for every container used, and safely dispose of empty containers.*
- 32.4 **NOTE:** *Store herbicides separately from other pesticides. Some herbicides may volatilize and contaminate the pesticides.*

33.0 Pesticide Cleanup

- 33.1 Always thoroughly clean all pesticide equipment as soon as you are through with it. Leaving pesticide residue in mixing, loading, or application equipment can result in accidental injury or death to livestock or people or unwanted contamination of plants or soil.
- 33.2 Clean the inside and outside of pesticide equipment, including nozzles. Dispose of contaminated rinse water as directed on the chemical label.
- 33.3 **IMPORTANT:** *Do not allow pesticide rinse water to contaminate water supplies.*



34.0 Antidotes

- 34.1 Time is of the essence when pesticide overexposure occurs. However, using an antidote kit may not be the best course of action. Unless a physician has stated that an antidote is needed, it should not be administered. Some antidotes such as atropine can be poisonous if misused. A prescription may even be necessary to acquire the antidote. You may be able to get a local physician to write the prescription, prepare a written protocol regarding the use of the antidote, and train pertinent employees about how and when to administer the antidote.
- 34.2 If medical assistance is available locally through a hospital, physician, or ambulance service, you should call 911 (or 9-911, from a campus phone) or take the individual directly to the nearest emergency treatment center instead of maintaining an antidote kit on site.



35.0 Fertilizer Chemical Safety



35.1 Ammonia fertilizers are widely used because of their effectiveness in getting large amounts of nitrogen into the soil. Anhydrous ammonia fertilizer is essentially dry ammonia gas compressed into liquid form. This material is very harmful if accidentally spilled or sprayed onto body surfaces. It can cause blindness if it gets into the eyes. Also, high concentrations of ammonia gas in the air are very irritating to the lungs. Always use appropriate personal protective equipment and exercise rigorous care when handling, applying, and storing such toxic or irritating materials.

35.2 Fertilizer Safety Precautions

35.2.1 Most ammonia fertilizer accidents occur when the material is being transferred from one tank to another. One of the major causes of accidents is hoses coming loose or bursting.



35.2.2 Exercise care in the handling and use of ammonia fertilizer by doing the following:

35.2.2.1 Always wear chemical goggles and adequate skin cover.

35.2.2.2 Inspect equipment before each day's work and correct any abnormal conditions.

35.2.2.3 Water is the first aid treatment of choice when ammonia gets into the eyes or on the skin. In case of mishap, flush affected areas for 15 minutes and get medical help as soon as possible.

35.2.2.4 Make sure all valves, lines, and connections are secure in order to reduce the chance of either leaks or being doused during transfer.

35.2.3 Observe these precautions when working with anhydrous ammonia:

35.2.3.1 Use good equipment specially designed for handling anhydrous ammonia.

35.2.3.2 Keep your equipment in good repair. Worn hoses, loose connections, and other defects can cause accidents.

35.2.3.3 Follow the prescribed sequence of operations for connecting to, filling, and disconnecting from the applicator tank.

35.2.3.4 Never leave the equipment during the transfer operation.

35.2.3.5 After filling the applicator tank, close all valves.

35.3 Storing Ammonium Nitrate



35.3.1 The guidelines listed below must be followed when storing ammonium nitrate fertilizer:

- 35.3.1.1 Not more than 60 tons of ammonium nitrate shall be stored.
- 35.3.1.2 Storage buildings shall have adequate ventilation.
- 35.3.1.3 All flooring in storage and handling areas shall be of noncombustible material, without open drains or traps.
- 35.3.1.4 Buildings and structures shall be dry and free from water seepage through the roof, walls, and floors.
- 35.3.1.5 Bags of ammonium nitrate shall not be stored within 30 inches of the storage building walls and partitions.
- 35.3.1.6 The height of piles shall not exceed 20 feet. The width of piles shall not exceed 20 feet.
- 35.3.1.7 Aisles shall be provided to separate piles by a clear space of not less than 3 feet in width.
- 35.3.1.8 Ammonium nitrate shall be stored separately from flammable or combustible materials (e.g. paper, rags, hay, oils).
- 35.3.1.9 Broken bags, spilled material, and discarded containers shall be promptly gathered and disposed.
- 35.3.1.10 Prohibit smoking where ammonium nitrate is stored.
- 35.3.1.11 Fire control devices such as a water hose or portable fire extinguishers must be available in the storage area.

35.3.2 Ensure that storage areas are equipped with mechanical devices so that workers are not required to enter the area.



END OF SECTION

XV. RADIATION SAFETY

1.0 Magnetic Resonance Imaging

- 1.1 The information in this section pertains only to large magnets at TAMIU such as those used for magnetic resonance imaging.
- 1.2 Because the magnetic flux lines (or *pull*) from the main magnetic field can extend well beyond the actual magnet, the greatest hazard associated with large magnets is the *missile effect*. Ferromagnetic objects such as pens, scissors, screwdrivers, oxygen cylinders, and other metallic devices can be pulled into the magnet with enough force to cause a serious injury or accident. In addition, magnetic fields may also disrupt pacemakers or cause injury to individuals with surgically implanted metal pins or plates.
- 1.3 **IMPORTANT:** *To protect bystanders and prevent the accidental introduction of ferromagnetic materials within the proximity of a magnet, establish a security zone around any large magnet.*



END OF SECTION

XVI. VEHICLE SAFETY

1.0 Utility Vehicle Operating Procedures Program

1.1 Subject: Utility Vehicles, Golf Carts, Club Cars, Gators, Tractors, Mowers and Four Wheel ATVs (Three Wheel ATVs not included).

1.2 This policy provides guidelines for the use of Utility Vehicles and/or similar slow moving vehicles (SMV) on the campus of Texas A&M International University. The intent is to enable operators to avoid situations that may compromise their safety and avoid damaging the vehicle or other property, as well as to promote a safer environment for students, faculty, staff, and visitors.



1.3 STATEMENT OF PROCEDURE

1.3.1 All members of the University community are covered by these procedures (students, staff, and faculty). All operators of Utility Vehicles must meet the following criteria before operating a Utility Vehicle on property under the jurisdiction of Texas A&M International University:

1.3.1.1 Possess a valid Texas driver's license.

1.3.1.2 Know and adhere to the State of Texas motor vehicle laws.

1.3.1.3 Attend utility cart training provided by the Office of Environmental Health and Safety.

1.3.2 Safety

1.3.2.1 All original equipment safety features must be kept in good working order.

1.3.2.2 The following outlines procedures for the safe operation of Utility Vehicles:

1.3.2.2.1 Supervisors must monitor and document that all persons operating Utility Vehicles have been instructed in the safe operation of Utility Vehicles.

1.3.2.2.2 Utility Vehicles are not to be overloaded, i.e. carrying more passengers than seating provided or overloading the Utility Vehicles recommended carrying or load capacity (Seat belts must be used when provided).

1.3.2.2.3 No one is permitted to ride on the running boards, fenders, or any part of the Utility Vehicle except the seats.

- 1.3.2.2.4 All body parts – feet, legs, and arms shall be kept inside the Utility Vehicle while it is in motion, unless the operator is signaling for a turn.
- 1.3.2.2.5 The MAXIMUM speed limit for Utility Vehicles off standard roadways is 10 mph (5 mph when pedestrians are present).
- 1.3.2.2.6 Utility Vehicles may operate on University roadways, but must adhere to posted speed limits. Utility Vehicles must operate only on University campus/property. All Utility Vehicles should travel in the right hand lane, unless turning left.
- 1.3.2.2.7 Pedestrians have the right-of-way on campus. Utility Vehicles must yield to pedestrians on sidewalks. **SPEED IS TO BE REDUCED TO A MINIMUM (5 mph max.) WHEN DRIVING ALONG OR CROSSING SIDEWALKS SO AS TO AVOID ACCIDENTS WITH PEDESTRIANS.**
- 1.3.2.2.8 Utility Vehicle operators are to be diligent and pay particular attention to the needs of disabled persons, as limitations in vision, hearing or mobility may impair their ability to see, hear, or move out of the way of Utility Vehicles.
- 1.3.2.2.9 Operators must park Utility Vehicles away from heavily traveled pedestrian areas.
- 1.3.2.2.10 Operators are not to block the path, limit pedestrian access on walkways, nor park at entrances to buildings.
- 1.3.2.2.11 Utility Vehicle operators are responsible for ignition keys for the period of time in which they are using the vehicle. Keys shall not be left in Utility Vehicles.
- 1.3.2.2.12 Exiting the utility vehicle
 - 1.3.2.2.12.1 Turn the key to “off” position.
 - 1.3.2.2.12.2 Engage brake.
 - 1.3.2.2.12.3 Remove the key.
- 1.3.2.2.13 University owned Utility Vehicles are to be used for University business only and cannot be removed from TAMU property without approval from the President or his designee.

1.3.2.2.14 No Utility Vehicle shall be operated between dusk and dawn without properly working headlights and taillights.

1.3.2.2.15 The operator must report any accidents to the University Police Department and to the operator's supervisor.

1.3.2.3 All Utility Vehicles and trailers (pulled by Utility Vehicles) must have clearly displayed on the exterior of that Vehicle and any trailer towed the slow moving vehicle reflective triangle.

This is an example of the required Slow Moving Vehicle Reflective Triangle:

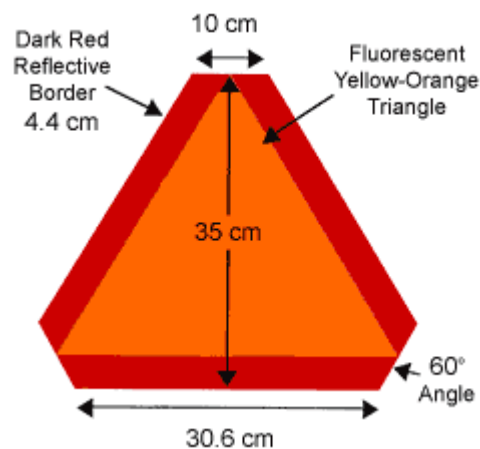

1.3.2.4 University owned Utility Vehicles are to be maintained in accordance with manufacturer's specifications.

1.3.2.4.1 Departments are responsible for keeping all original equipment and safety features in good working order.

1.3.2.4.2 Modification or tampering with a Utility Vehicle governor is prohibited and is a violation of Federal Law.

1.3.2.5 Personally owned Utility Vehicles are prohibited from operating on University property.

1.3.3 The safe operation of Utility Vehicles is paramount. Failure to follow this procedure, render common practices or courtesies, or follow rules of the road for the State of Texas, could result in citation, appropriate disciplinary action, and/or suspension of operator's Utility Vehicles driving privileges.

2.0 General Vehicle Safety

- 2.1 Motor vehicle accidents are the leading cause of death and crippling injury in the United States. Traffic safety laws are important components of vehicle safety, but the most important aspect of vehicle safety is the driver.

IMPORTANT: All TAMIU employees who operate a motor vehicle for company business (whether a company vehicle, rental vehicle, or personal vehicle) must possess a valid state driver's license for their vehicle's class.

- 2.2 The University Police Department is responsible for regulating moving vehicles and bicycles on university property. To ensure driving safety, follow these driving practices:

- 2.2.1 Never drink and drive. Driving while under the influence of alcohol or drugs is strictly prohibited.
- 2.2.2 Obey all traffic laws, signs, and signals.
- 2.2.3 Respond to dangerous driving conditions as appropriate.
- 2.2.4 Maintain a safe distance between your car and any car in front of you. Allow at least one car length for each 10 MPH (e.g., three car lengths if you are driving 30 MPH).
- 2.2.5 Keep your eyes moving to avoid fatigue, especially if you plan on driving for a long period.
- 2.2.6 Always use your turn signal to indicate your intended action.
- 2.2.7 Leave yourself an "out" by either driving in the lane with a shoulder, driving in the middle lane of a multi-lane road, or following other vehicles at a safe distance.
- 2.2.8 Safety belts must always be worn when available in the vehicle.



3.0 Defensive Driving

- 3.1 By taking defensive driving courses, employees can promote driving safety and lower their insurance rates. The principles of defensive driving include the following:
- 3.1.1 **Knowledge:** Know your vehicle and know the law.
- 3.1.2 **Control:** Always maintain control of your vehicle. To improve your control, perform routine vehicle maintenance and respond to road conditions as appropriate.
- 3.1.3 **Attitude:** Be willing to obey all laws and be willing to yield to all other vehicles and pedestrians.
- 3.1.4 **Reaction:** Respond to driving conditions appropriately. Do not impede your reaction time by driving when tired or under the influence of alcohol or drugs.
- 3.1.5 **Observation:** Be aware of potential accidents and take preventive measures. Always try to anticipate the actions of other drivers.

- 3.1.6 **Common Sense:** Do not risk your safety to save time. Do not respond to rude or obnoxious drivers by violating traffic laws.

4.0 Backing Vehicles

- 4.1 Backing a large vehicle can be very difficult. Try to avoid backing whenever possible. If you must back a vehicle, follow these guidelines:
 - 4.1.1 Get out of the vehicle and inspect the area you want to back into.
 - 4.1.2 If possible, have someone outside help guide your vehicle into position.
 - 4.1.3 If your vehicle does not automatically sound a horn when in reverse, sound the horn once before moving backwards.
 - 4.1.4 Back slowly and check your mirrors often.

5.0 Accidents

- 5.1 If you are ever involved in a vehicle accident, follow these guidelines.



- 5.1.1 Check for injuries. If anyone is injured, immediately call the police and EMS (326-2911 or 2911 from a University telephone).
- 5.1.2 If there are no injuries, you are blocking traffic, and your car can be driven, move the car to a safe location nearby. (If the accident occurs on a freeway lane, ramp, shoulder, median, or busy metropolitan street, you *must* move your car if it is safe and possible to do so.)
- 5.2 If you cannot move your car, try to warn oncoming traffic to prevent other accidents:
 - 5.2.1 Raise your hood.
 - 5.2.2 Turn on your hazard lights.
 - 5.2.3 Light flares.
- 5.3 Exchange the following information with other drivers involved in the accident:
 - 5.3.1 Name, address, and phone number
 - 5.3.2 Vehicle identification number, license number, and description
 - 5.3.3 Insurance information
 - 5.3.4 Driver's license number
- 5.4 Call the police in the following circumstances:
 - 5.4.1 Someone is injured.
 - 5.4.2 A car cannot be moved.
 - 5.4.3 A driver is intoxicated.
 - 5.4.4 A driver has no insurance.

5.4.5 A driver leaves the scene of the accident without exchanging information.

6.0 Railroad Crossings

6.1 Compared with other types of collisions, train/motor vehicle crashes are 11 times more likely to result in a fatal injury. On the average, there are more train-car fatalities each year than airplane crashes. Unfortunately, driver error is the principal cause of most grade crossing accidents. Many drivers ignore the familiar tracks they cross each day, and some drivers disregard train warning signals and gates.



6.2 All public highway-rail grade crossings are marked with one or more of the following warning devices:

6.2.1 **Advance Warning Signs:** Advance warning signs indicate that a railroad crossing is ahead. These signs are positioned to allow enough room to stop before the train tracks.

6.2.2 **Pavement Markings:** Pavement markings may be painted on the pavement in front of a crossing. Always stay behind the stop line when waiting for a passing train.

6.2.3 **Crossbuck Signs:** Railroad crossbuck signs are found at most public crossings. Treat these signs as a yield sign. If there is more than one track, a sign below the crossbuck will indicate the number of tracks at the crossings.

6.2.4 **Flashing Lights and Gates:** Flashing lights are commonly used with crossbucks and gates. Stop when the lights begin to flash and the gate starts to lower across your lane. Do not attempt to cross the tracks until the gate is raised and the lights stop flashing.



IMPORTANT: You must stop at least 15 feet from a train track when: (1) warning lights flash; (2) a crossing gate or flagperson signals an approaching train; (3) a train is within 1500 feet of the crossing; or (4) an approaching train is plainly visible and in hazardous proximity.

6.3 Follow these guidelines when you encounter a railroad crossing:

6.3.1 Always expect a train.

6.3.2 Always be aware of your surroundings.

6.3.3 When approaching a crossing, LOOK, LISTEN, and LIVE.

6.3.4 Be sure all tracks are clear before you proceed. Remember, due to their large size, it is easy to misjudge the speed and distance of an oncoming train. If you have any doubts, stop and wait for the train to pass.

6.3.5 Watch for vehicles, such as school buses and hazardous material transport vehicles that must stop before train tracks.

- 6.3.6 Never race a train to a crossing.
- 6.3.7 Always stop for flashing lights, bells, and gates. Never drive around a gate. (State law requires pedestrians to stop when a railroad crossing gate is down.)
- 6.3.8 Do not allow yourself to be boxed in on a track with cars in front and behind you.
- 6.3.9 Never stop on train tracks. If your car stalls on train tracks, call 911 immediately. If a train approaches, abandon the car and run away from the tracks.
- 6.3.10 When driving at night, look low to the ground for moving trains. (One third of all train-car collisions occur at night when cars run into moving trains.)
- 6.3.11 Watch out for a second oncoming train after the first train has passed.

7.0 Bicycle Safety

7.1 Each year there are 700 fatalities and 39,000 injuries among cyclists in the U.S. Cyclists must take precautions when driving on city and University streets.

7.2 Follow these safety precautions when riding a bicycle:

7.2.1 Always obey *all* traffic laws:



7.2.1.1 Stop at stop signs.

7.2.1.2 Ride in the correct direction on one-way streets. Stop at railroad tracks when the warning signals are operating.

7.2.2 When riding with other cyclists, ride single file in traffic.

7.2.3 When bike lanes are available, use them. If bike lanes are not available, stay as far right as possible on the street pavement. Watch for opening car doors, sewer gratings, debris, etc. Do not ride on sidewalks.

7.2.4 Use hand signals when turning or changing lanes.

7.2.5 Wear a helmet that is approved by ANSI or the Snell Memorial Foundation. (Head injuries account for 75% of all cycling fatalities.)



7.2.6 If riding at night, make sure your bicycle has reflectors on the rear, front, spokes, and pedals. Wear bright, reflective clothing.

7.2.7 Do not take bicycles into TAMIU buildings; park safely in the designated bicycle parking areas located throughout the campus.

END OF SECTION

XVII. GROUNDS MAINTENANCE

1.0 General Lawn Safety

- 1.1 TAMIU spends considerable time, effort, and money on grounds maintenance. From flower care, to lawn care, tree trimming, and leaf blowing, TAMIU employees are responsible for safely maintaining the grounds on campus. Gardening tools and mechanical lawn care devices, such as lawn mowers, power blowers, and chain saws, present special safety concerns for grounds maintenance personnel.



- 1.2 Common landscaping accidents include the following:
- 1.2.1 Cuts, lacerations, or amputations from whirling mower blades.
 - 1.2.2 Bruises or broken bones from flying projectiles.
 - 1.2.3 Burns from hot equipment parts
 - 1.2.4 Electrical shock from faulty grounding or defective electrical cords
 - 1.2.5 Back strain from improper equipment usage
 - 1.2.6 Slips, trips, and falls
- 1.3 Regardless of the type of landscape equipment you use, follow these basic guidelines to ensure optimum safety:

- 1.3.1 Read the equipment owner's manual.

- 1.3.1.1 Use the right equipment for the job at hand.
- 1.3.1.2 Inspect the equipment before each use.
- 1.3.1.3 Know how to control and stop the equipment quickly.

- 1.3.2 Wear personal protection equipment, as necessary:

- 1.3.2.1 Eye protection
- 1.3.2.2 Hearing protection
- 1.3.2.3 Long pants
- 1.3.2.4 Sturdy, close-toed shoes
- 1.3.2.5 Work gloves
- 1.3.2.6 High visibility safety apparel



- 1.3.3 Apply sunscreen to exposed areas of skin.
- 1.3.4 Be careful to avoid fatigue and heat stress (refer to the General Safety chapter in this manual for more information):

- 1.3.4.1 Drink plenty of water (5-7 oz. every 20 minutes)

1.3.4.2 Take breaks

- 1.3.5 Do not operate powered equipment if you are tired, sick, or taking medication.
- 1.3.6 Take special precautions when working with electrical equipment. If you are using an extension cord, take care not to accidentally cut it.
- 1.3.7 Do not smoke around gas powered equipment. Allow hot equipment to cool before refueling.

1.4 Make sure that all guards are in place and in good condition.

IMPORTANT: *Keep pedestrians and bystanders at least 30 feet away when using powered equipment.*

- 1.5 Follow manufacturers instructions prior to conducting maintenance activities on any equipment.



2.0 Hand Tools

- 2.1 Although garden hand tools tend to be safer than powered equipment, common gardening tools, such as rakes, shovels, and hoes cause thousands of injuries each year. Follow these guidelines for using garden hand tools.



- 2.1.1 Keep hand tools in good condition. Replace split or rotten handles. Keep blades sharp.
- 2.1.2 Buy quality tools that fit your needs and your build. For example, if you are tall, choose tools with handles that are long enough to prevent you from stooping over your work.
- 2.1.3 Never leave a rake, shovel, or hoe on the ground facing up. Foot injuries from exposed metal and head injuries from handles that pop up unexpectedly are the main hazards associated with these tools.

3.0 Mower Safety

- 3.1 Mowers are the most common type of lawn care equipment. To avoid injury with power mower equipment, you must pay close attention to your surroundings. Whether you use a riding mower or a walk-behind mower, follow these guidelines for lawn mower safety:

- 3.1.1 Conduct a pre-mowing inspection of the lawn and remove any debris, rocks, limbs, or other items that could become a projectile. Look for concealed hazards such as holes.
- 3.1.2 Keep hands and feet away from moving blades.



- 3.1.3 Fill the tank with gas before beginning work. (By filling the tank initially, you can avoid having to fill the tank later when it is hot.)
- 3.1.4 Replace loud or faulty mufflers.
- 3.1.5 Shut off the engine before unclogging, servicing, or adjusting the mower and before removing the grass bag. For added protection, remove the ignition wire before working on the machine.
- 3.1.6 Inspect mower to verify all guards and safety devices are in place and operating properly.

4.0 Riding Lawn Mowers

- 4.1 In addition to the general guidelines for mower safety, follow these guidelines for riding lawn mower safety:



- 4.1.1 Before starting the engine, make sure the transmission is out of gear and the mower blade clutch is disengaged.
- 4.1.2 Never allow extra riders on the lawn mower.
- 4.1.3 Slow down when turning and when working on slopes. Mow up and down slopes rather than across them.
- 4.1.4 Always look behind you before backing.
- 4.1.5 If you hit a large rock or stump, stop the mower and inspect the blades and shaft. Replace damaged blades.
- 4.1.6 Never leave a running lawn mower unattended. Before leaving the seat, park the mower on a flat area, disengage the mower blades, and remove the ignition key.

5.0 Walk-Behind Mowers

- 5.1 In addition to the general guidelines for mower safety, follow these guidelines for walk-behind mower safety:



- 5.1.1 Wear sturdy shoes with good traction. Never wear open-toed shoes around walk-behind mowers.
- 5.1.2 Do not bypass the safety device that stops the blade when the operator releases his/her grip on the handle.
- 5.1.3 Mow across slopes rather than up and down slopes.
- 5.1.4 Work slowly and patiently when mowing tall grass or tough weeds. Forcing the mower may cause repeated clogs and engine stalls.
- 5.1.5 Never leave a running mower unattended. If you stop momentarily, cut the throttle to idle and make sure the mower will not roll away.

6.0 Chain Saw Safety

6.1 Chain saws are ideal for trimming trees and cutting fallen limbs into smaller pieces. Unfortunately, chain saws are associated with many serious injuries each year. Common chain saw hazards include the following:

- 6.1.1 Chain cuts
- 6.1.2 Falling trees and limbs
- 6.1.3 Strains and sprains
- 6.1.4 Burns



6.2 To avoid injury, you must respect chain saw hazards and handle chain saws skillfully. In addition to general lawn safety guidelines, follow these instructions for safely using chain saws:

- 6.2.1 Stay alert while sawing. Most injuries occur below the waist when the operator is not paying attention.
- 6.2.2 Do not use a chain saw alone. Have someone else stand nearby in case of an emergency.
- 6.2.3 Choose and inspect your chain saw carefully:

- 6.2.3.1 Use the correct size chain saw for the job at hand.
- 6.2.3.2 Ensure that the chain is sharp and the tension is taut.
- 6.2.3.3 Ensure that smaller chain saws have a safety tip to prevent kickbacks. (Kickbacks cause one third of all chain saw injuries.)

6.2.4 Wear protective safety equipment as necessary:

- 6.2.4.1 Hard hat
- 6.2.4.2 Eye protection
- 6.2.4.3 Face shield
- 6.2.4.4 Hearing protection
- 6.2.4.5 Gloves
- 6.2.4.6 Chainsaw protective chaps



- 6.2.5 Always operate a chain saw with two hands.
- 6.2.6 Limbs that are at shoulder height or higher present a special safety problem. Use a ladder so that the saw is at a lower and safer position relative to your body.
- 6.2.7 Never allow the tip of a running chain saw to touch the ground. This could cause a serious kickback injury.
- 6.2.8 To avoid kickback injuries, stand to the side of a running chain saw. Do not stand directly behind it.
- 6.2.9 Move brush and limbs as you work to maintain a clear operating area.
- 6.2.10 Never force a chain saw through a limb.
- 6.2.11 Never stand on a log or limb while cutting it.



7.0 Power Blowers

- 7.1 Because power leaf blowers produce air gusts up to 200 mph, you must follow *all* manufacturers' safety precautions. Always walk towards your work when using a power leaf blower. Do not back away from your work.
- 7.2 Always wear hearing and eye protection when operating a blower.

8.0 Trimming Equipment

- 8.1 Follow these safety guidelines for trimming equipment such as hedge trimmers, string trimmers, grass shears, and edgers:
 - 8.1.1 Avoid touching rocks, debris, and gravel with trimming equipment. These items could cause a serious injury if a kickback occurs.
 - 8.1.2 Make sure all screws and chains are tight. Vibrating equipment can cause screws to loosen.
 - 8.1.3 Walk towards your work. Do not back away from your work when using a trimmer.



9.0 Chemical Products

- 9.1 Information on the safe use of pesticides (insecticides, herbicides, etc.) and fertilizers is given in Chapter 15, Agriculture Safety, of this manual.

END OF SECTION

XVIII. Environmental Management

1.0 Environmental Management

- 1.1. Environmental Management on campus involves managing the impact that we have on the environment. The Environmental Advisory Committee reviews and drafts environmental policy and programs to assist the University with improving compliance, pollution prevention, environmental education, stewardship, and sustainability. Information on the committee and its activities can be found by contacting the Office of EH&S.
- 1.2. Environmental impacts are well regulated by both the Texas Commission on Environmental Quality (TCEQ) and the Environmental Protection Agency (EPA). Environmental Health and Safety has developed programs to help the campus comply with the regulations and reduce its impact on the environment.

2.0 Hazardous Waste Program

- 2.1 The intent of the Texas A&M International Hazardous Waste Program is to protect water, land, and air by providing a means to handle and dispose of hazardous waste using environmentally sound methods. The program helps employees at Texas A&M International determine what is considered a hazardous waste, how to label and store the waste, and ultimately what is needed to have the waste disposed. It can be found in its entirety at http://www.tamtu.edu/adminis/safety/LAB_SAFETY.shtml

3.0 Pollution Prevention Plan

- 3.1. In an effort to reduce the amount of waste on campus and its impact on the environment, Texas A&M International has developed a Pollution Prevention Program. The goal of this program is to reduce the amount of material that becomes waste through increasing process efficiency and discouraging unnecessary chemical purchases. The program also looks into ways of improving waste disposal by giving preference to recycling and treatment that may prevent the waste from going to a landfill. Details about the program can be found by contacting EHS at (956) 326-2756 or email at safety@tamtu.edu.

4.0 Storm Water Management

- 4.1. Improper management of storm water can cause damage and pollution to our natural resources. A Storm Water Management Plan was created for the University to reduce the effects that our activities have. The plan includes public education and involvement, inspections, litter control, spill prevention, and structural controls. For further information about the Storm Water Management plan, please contact EHS at (956) 326-2756 or email at safety@tamtu.edu.

5.0 Spill Prevention Control and Countermeasures

- 5.1. Our Spill Prevention Control and Countermeasure Plan (SPCC) is designed to compliment this effort by preventing spills from accruing and reducing their impact on the environment when they do occur. This plan has requirements for bulk storage of certain chemicals, training, emergency response, and decontamination procedures. For more information about the SPCC, please contact EHS at (956) 326-2756 or email at safety@tamiu.edu.
- 5.2. To report a chemical spill, contact the Office of EH&S by called (956) 326-2756 during business hours or UPD Dispatch at (956) 326-2911 after business hours.

END OF SECTION

XIX. Hazardous Materials Transportation

1.0 General

1.1 The US Department of Transportation (DOT) and the International Air Transport Association (IATA) have detailed regulations for shipping hazardous materials or dangerous goods. When shipping within the United States or internationally, it is critical to comply with all shipping regulations to protect the shipper, the carrier, and the environment to prevent stiff penalties from being imposed.



1.2 All ‘hazmat employees’ require some level of training specific to the transportation-related function they perform (i.e. classification, packaging, marking, labeling, paperwork, etc). It is crucial that Texas A&M International University (TAMIU) personnel responsible for shipping are properly trained to package and ship their materials.

2.0 The Regulations

2.1 The Hazardous Materials Regulation (HMR) Parts, 171 – 180 of Title 49 CFR contain all the regulations pertaining to the transport of hazardous materials. The purpose of the HMR is to provide the shipper with instruction on how to properly package, mark, label and document a hazardous material to be placed in commerce (i.e. ground, air, water and rail).

2.2 The International Air Transport Association’s Dangerous Goods Regulation is the guide that is recognized by all airlines that carry dangerous goods in all countries. This regulation provides procedures for the shipper and the operator by which Dangerous Goods can be safely transported by air on all commercial air transport.

2.3 Both regulations serve the same purpose, to provide safety to the shipper and carrier and to minimize the risk of contamination to the environment.

3.0 Who Needs Training?

3.1 A “hazmat employee” is a person who is employed by a hazmat employer (TAMIU) and who directly affects hazmat transportation safety. At TAMIU this is a person who:

- 3.1.1 Loads, unloads, or handles hazardous materials;
- 3.1.2 Classifies hazardous materials, prepares hazmat packages and/or shipping papers for transport by carriers; and/or
- 3.1.3 Is responsible for safely transporting hazardous materials in university vehicles.

4.0 What Training is Offered?

4.1 Only trained persons may ship or receive shipments of hazardous materials / dangerous goods. The following trainings are available through Environmental Health and Safety:

4.1.1 General Awareness – This training enables the employee to recognize and identify hazardous material shipments. The training is consistent with the hazard communication program required by 49 CFR.

4.1.2 Dry Ice Shipping – This training is specific to shipments of Dry Ice. Dry Ice is a regulated hazardous material / dangerous good when shipped by air and therefore requires special packaging, marking and labeling.

4.1.3 Limited Quantities – Limited quantities are shipments that must meet specific requirements (e.g. a specific amount) in order to be classified as a limited quantity shipment. This training will assist in classification, packaging, marking, labeling and documentation of a limited quantity shipment.



4.1.4 Excepted Quantities – These shipments are materials that are less than 30 milliliters or 30 grams of a hazardous material. This training will assist in classification, packaging, marking, labeling and documentation of a limited quantity shipment.

4.1.5 Function Specific Training – Function specific training is for individuals shipping specific hazardous materials repetitively and focuses on the needs of the shipper. This training is available as requested and developed for the specific needs of the shipper.

4.1.6 Annual Contracted Training – A 40 hour Hazardous Material Transportation course is offered at the beginning of each year. Each department that ships hazardous materials is encouraged to have at least one person attend the 40 hour course. The training consists of 24 hours of 49 CFR, eight hours of the IATA Dangerous Goods Regulation, eight hours of Infectious Substance Training or Radioactive Material Training.

4.1.7 Refresher Training – DOT requires refresher training every three years. IATA requires refresher training every two years. To ensure Texas A&M International meets the refresher training requirements as required by both regulations, the Texas A&M International Hazardous Materials Shipping Program requires anyone shipping hazardous materials to be retrained every two years.

5.0 Hazardous Materials Defined

5.1 Hazardous materials mean a substance or material that the Secretary of Transportation has determined is capable of posing an unreasonable risk to health, safety, and property when transported in commerce, and has been designated as hazardous under Section 5103 of the Federal Hazardous Materials Transportation Law (49 U.S.C. 5103). Hazardous materials, for the purpose of transportation, are those in one or more one of the following groups:

- 5.1.1 Explosive materials
- 5.1.2 Gases
- 5.1.3 Flammable liquids
- 5.1.4 Combustible liquids
- 5.1.5 Flammable or & water-reactive solids
- 5.1.6 Oxidizers
- 5.1.7 Poisonous materials
- 5.1.8 Infectious materials
- 5.1.9 Radioactive materials
- 5.1.10 Corrosive materials
- 5.1.11 Miscellaneous hazardous materials

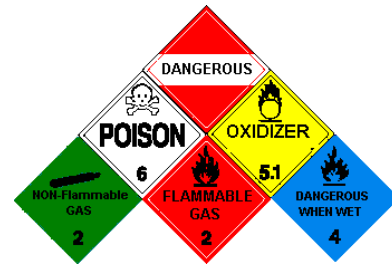

6.0 DOT Requirements Simplified

6.1 The DOT regulations stipulate

- 6.1.1 how a hazardous material is **packaged** (e.g., cardboard box, metal drum);
- 6.1.2 how the package is **marked**--what words are written on the side;
- 6.1.3 how the package is **labeled**--what colored diamond-shaped label is applied;
- 6.1.4 how the material is **described** on shipping papers, which are required for shipment.
 - 6.1.4.1 This information is summarized in the Hazardous Material Table in section 172.101 of the DOT regulations
 - 6.1.4.2 It is important to note that just because the material you are shipping is not listed in the hazardous materials table does not imply that the material you are shipping is not regulated.
 - 6.1.4.3 If you are unsure of the classification of your material, always contact EHS.

7.0 Hazardous Materials Shipping Questions

7.1 For assistance in resolving questions about the proper shipment of hazardous materials contact Environmental Health and Safety – (956) 326-2756.

END OF SECTION

INDEX

Accident Reporting	4
Accidents	165
Acids and Alkalis	7
Administration	2
Aerosol Sprays	7
Agriculture Safety	138
Americans with Disabilities (ADA)	4
Antidotes, Pesticide	157
Appliances	88
Applying Pesticides	154
Appropriate Apparel	6
Areas that Need Barriers or Guards	59
Arm and Hand Protection	108
Arson	88
Asbestos	5
Avoiding Electrical Hazards with Hoists	62
Backhoes	61
Backing Vehicles	165
Barriers and Guards	58
Bicycle Safety	167
Biological Safety	116
Biological Safety Program	116
Body Protection	109
Building Evacuations/Drills	88
Bypass Starting	148
Candles & Incense	89
Chain Saw Safety	171
Chemical Products	172
Chemical Safety	117
Chemical Safety Guidelines	119
Chemical Safety Hazard Communication Program	117
Chemical Safety Hazard Identification	118
Chemical Safety Overview	117
Chemical Storage Guidelines	122
Chemical Waste Disposal	137
Circuit Breaker Loads	49
Cleanup, Pesticide	157
Combustible Storage	89
Compressed Gas Cylinders	90
Confined Space	85
Confined Space Definition and Locations	85

INDEX

Confined Space Policy	85
Confined Space Reason	85
Confined Space Training	86
Construction and Renovation	90
Construction Safety	58
Cutting Guidelines	47
Decorations	90
Defensive Driving	164
Disposal, Pesticide	157
Drill Press Safety	37
Ear and Hearing Protection	109
Electrical Emergency Response	51
Electrical Grounding	49
Electrical Panels	50
Electrical Safety	48
Electrical Safety	91
Electrical Safety Definitions	48
Electrical Safety Guidelines	50
Emergency Access and Egress	91
Emergency Management Purpose	103
Emergency Management Roles and Responsibilities	103
Emergency Management Training Resources	106
Emergency Management	103
Employees and Students	2
Environmental Health and Safety	1
Environmental Management	173
Environmental Management	173
Equipment and Furniture Safety	24
Equipment Arrangement	28
Examples of a Confined Space	86
Eye and Face Protection	110
Faculty, staff and Students	2
Fall Protection Procedures	64
Farm Field Equipment	140
Farmstead Equipment	140
Fertilizer Chemical Safety	157
Fertilizer Safety Precautions	158
Fire & Life Safety	87
Fire and Life Safety Inspections	97
Fire and Life Safety Program	87
Fire and Life Safety Program Requirement	87
Fire and Life Safety Applicable Codes & Standards	87
Fire Control, Pesticides	156
Fire Detection and Notification	93
Fire Doors	94
Fire Extinguishers	95
Fire Hydrants	97
Fire Lanes	97

INDEX

Fire Prevention	98
Fire Reporting	98
Fire Suppression	99
Flammable and Combustible Liquids	92
Foot Protection	110
Forging Machines	42
Forklifts	60
Fuel Storage	141
General Construction Guidelines	58
General Electrical Safety	48
General Farm Equipment Safety	139
General Lawn Safety	168
General Office Safety	21
General Pesticide Safety	152
General Safety	4
General Safety Guidelines	115
General Shop Safety	30
General Tips for a Safe Working Environment	138
General Tractor Safety	144
General Vehicle Safety	163
Good Housekeeping Practices	21
Grain Augers	140
Grain Storage	143
Graphic Arts Media	6
Grinder Safety	38
Grounds Maintenance	168
Guards	36
Guards, Shields and PTO's	141
Hand Tools	33
Hand Tools	169
Hazardous Materials Defined	177
Hazardous Materials DOT Requirements Simplified	177
Hazardous Materials General	175
Hazardous Materials Shipping Questions	177
Hazardous Materials The Regulations	175
Hazardous Materials Transportation	175
Hazardous Materials What Training is Offered	176
Hazardous Materials Who Needs Training	175
Hazardous Objects and Materials	22
Hazardous Waste Program	173
Head Protection	111
Hearing Conservation Program	9
Hearing Loss	10
Heat Exhaustion	12
Heat Stress and Heat Strain	12
Heat Stroke	13
Heavy Equipment Safety	60
High Voltage Procedures	56

INDEX

Hoisting Guidelines	62
Hoists	62
Hot Work Permit	38
Housekeeping	14
Hydraulic Equipment Safety	140
Hygiene and Chemical Safety	124
Indoor Air Quality	14
Inspecting Hoists	63
Insulation	34
Introduction	1
Introduction to Agricultural Safety	138
Job Safety	31
Jointer and Shaper Safety	40
Laboratory Safety	115
Ladders	34
Lathe Safety	40
Lead Paint	16
Lifting	16
Liquefied Petroleum Gas	142
Liquefied Petroleum Gas (LPG)	100
Lockout/Tag-out Procedures	52
Magnetic Resonance Imaging	160
Material Safety Data Sheets	120
Minimum Clear Working Space	57
Mixing Pesticides	154
Mobile Crane Safety Procedures	63
Mower Safety	169
Nail/Air Gun Safety (Pneumatic Fastening Tools)	41
Office Safety	21
Open Burning	101
Operational Procedures	156
Operator's Position	27
Paints and Pigments	7
Personal Protection	30
Personal Protective Equipment	108
Personal Protective Equipment Defined (PPE)	108
Pesticide Chemical Safety	150
Pesticide Safety Precautions	156
Pesticide Storage and Disposal	155
Phases of Emergency Management	103
Photography	8
Picking Up Loads with Hoists	62
Planer Safety	42
Plastics, Acrylics, Epoxy Resins	8
Pollution Prevention Plan	173
Polychlorinated Biphenyls (PCBs)	18
Portable Fuel Tanks	142
Pottery and Ceramics	9

INDEX

Power Blowers	172
Power Tools	34
Preparing to Apply Pesticides	153
Preventing Cuts and Punctures	22
Preventing Machine Accidents	22
Preventing Slips and Falls	19
Preventing Slips and Falls	23
Preventing Stress	24
Protecting Oneself When Working with Chemicals	137
Pyrotechnics/Open Flames	102
<i>Radiation Safety</i>	160
Railroad Crossings	166
Remember the Following Points	139
Respiratory Protection Program	111
Respiratory Safety	112
Respiratory Selection	112
Respiratory Usage Requirements	112
Riding Lawn Mowers	170
Roll-over Protective Structures (ROPs)	146
Safe Handling Guidelines	121
Safety Guidelines	32
Safety Guidelines (needs to be renamed)	37
Safety Manual	3
Sander Safety	43
Saw Safety	43
Scaffolding	73
<i>Shop Safety</i>	30
Site Storage	155
Smoking	20
Smoking	102
Solvents	6
Space Heaters	102
Spill Prevention Control and Countermeasures	174
Spray Paint Booths	44
Stationary Fuel Storage Tanks	141
Storage Facility	155
Storing Ammonium Nitrate	158
Storm Water Management	173
Summoning Emergency Services	105
Supervisors, Department Heads and Directors	2
Towing Safety	149
Tractor Driving Safety	144
Tractor Hauling Safety	150
Transporting Hazardous Materials	137
Trenching	74

INDEX

Trimming Equipment	172
Types of Barriers and Guards	58
Types of Chemical Hazards	125
Using Barriers and Guards	59
Utility Vehicle Operating Procedures Program	161
Vehicle Safety	161
Visitor Safety	20
Walk-Behind Mowers	170
Warning Systems	106
Welding and Cutting	45
Welding Guidelines	46
Woodworking	9
Work in a Confined Space	86
Work Station Arrangement	27